



IWAKI
MAGNETIC
DRIVE
PUMPS

MXM



Patent

JAPAN / U.S.A. / TAIWAN / EU / CHINA

Solution for chemical handling applications



Better withstanding difficult operating conditions

The proven non-contact system and self-radiating bearing structure deliver substantial improvements in tolerance of dry running and poor suction conditions.

Non contact system

Unlike conventional magnetic drive pumps, the MXM series are designed to prevent contact between the bearing and the rear thrust faces, even during dry running. By preventing contact, the rear thrust ring minimizes heat generation to prevent melting of plastic parts.

Self radiation structure (PAT.)

Through heat-dispersion holes provided in the fixed portions of the impeller and the magnet capsule, the liquid around the spindle and the bearing is forced to circulate so that heat generated by sliding can be reduced effectively. Thus, thermal deformation and melt are prevented.

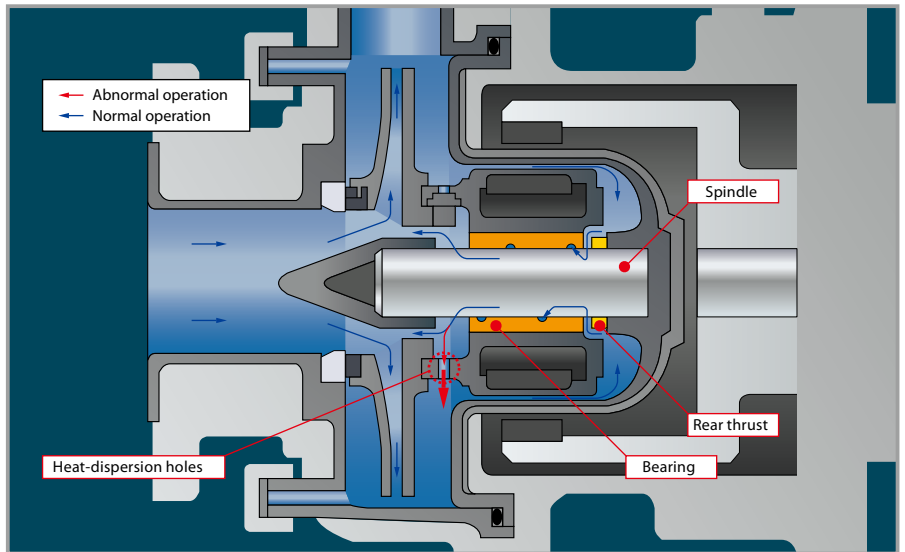

Magnetic drive pumps with an excellent balance of features and performance

The MXM series of pumps have now been added to the line-up of Iwaki's magnetic drive process pumps, which have earned high acclaim and the trust of users all around the world. The new MXM series feature an excellent balance of the characteristics required of chemical pumps, including corrosion resistance, durability and safety. They employ a non-contact, self-radiating bearing structure to better withstand difficult operating conditions. The advent of the MXM series has further expanded the array of choices offered by Iwaki's process magnetic drive pumps.

Exceptional corrosion resistance

The MXM series employ optimum anti-corrosive materials such as carbon fiber reinforced ETFE (CFRETFE), high quality ceramic and carbon for parts that come in contact with liquid. The most suitable impeller size and motor output can be selected for the required liquid property.



Impeller+Magnet capsule



Spindle+Bearing

Robust structure

The pumps have an external armour of high strength ductile cast iron for use in heavy duty chemical process applications. The sealing performance between the front casing and the rear casing is drastically enhanced by our original structure (patent pending), offering high reliability.



Cover+Front casing

Enhanced safety

The MXM features a unique rear casing shape designed to prevent stress concentration. This increases both the pump's pressure resistance and the mechanical strength of the spindle support. The high temperature model uses a dual structure incorporating an FRP rear casing cover. In addition to further increasing the pump's pressure resistance, it improves safety with dual containment preventing liquid leakage in the event of unexpected damage to the rear casing.



Rear casing+Rear casing cover (Option)



MXM44

MXM22



Construction and materials

Part	Material code	CF	FF	KK
1 Front casing	CFRETFE			
2 Rear casing				
3 Impeller				
4 Magnet capsule				
5 Spindle	High-purity alumina ceramic			SiC
6 Bearing	High-density carbon	High-purity alumina ceramic		
7 Liner ring	High-purity alumina ceramic			
8 Mouth ring	PTFE with filler			
9 Rear thrust		MXM22/44: CFRETFE, MXM54: CFRPFA		
10 O ring		FKM/EPDM/AFLAS®/ DAI-EL PERFLUORO®		
11 Lock pin	Note	CFRETFE		

Note: 54 type only

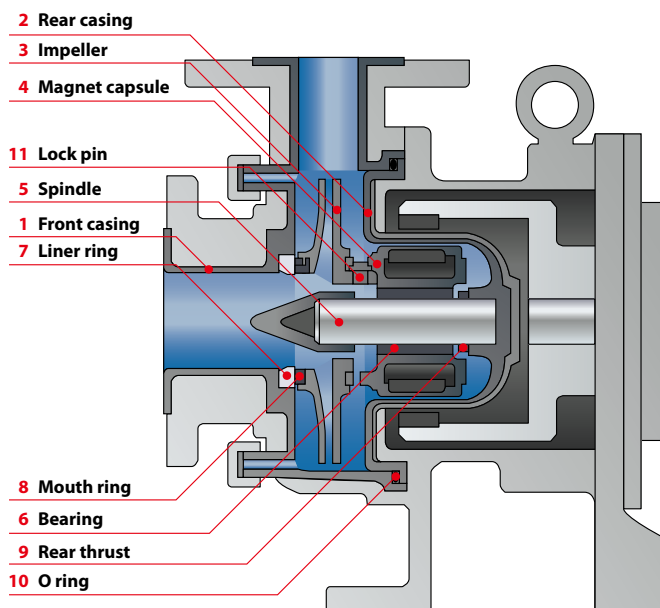

Specifications

Model	Pump size Suction × Discharge	50Hz			60Hz		
		Impeller size	Capacity L/min	Head m	Impeller size	Capacity L/min	Head m
MXM22 (Impeller range 1)	25mm × 25mm	100	150	7.5	080	150	6.5
		090	150	5.5	070	150	5
		070	150	2.5	–	–	–
MXM22 (Impeller range 2)	25mm × 25mm	105	150	8	105	150	14
		–	–	–	090	50	12
MXM44 (Impeller range 1)	40mm × 40mm	115	200	9.5	120	200	17
		110	200	8	105	200	11
		100	200	6	095	200	9.5
		090	200	5	085	200	7.5
		–	–	–	075	200	5
MXM44 (Impeller range 2)	40mm × 40mm	130	200	12	130	100	25
MXM54 (Impeller range 1)	50mm × 40mm	150	200	18.5	150	200	30.5
		140	200	17	140	200	27.5
		120	200	13.5	–	–	–
MXM54 (Impeller range 2)	50mm × 40mm	–	–	–	130	200	21.5
		–	–	–	120	200	19
		–	–	–	110	200	15
MXM54 (Impeller range 3)	50mm × 40mm	150	300	20	130	300	26
		140	300	18.5	120	300	20.5
		130	300	16.5	–	–	–
		110	300	10.5	–	–	–
MXM54 (Impeller range 4)	50mm × 40mm	150	400	25	150	200	41
		140	400	20.5	140	400	29.5
		125	400	15.5	130	400	25
		110	400	9.5	120	400	21.5

Note1: Liquid temp. range

Standard: -10 to 90 °C High temp. version (with rear casing cover): -10 to 105 °C (10 to 105 °C when AFLAS® O ring is used)

Note2: Max operating pressure

Standard MXM22: 0.2MPa, MXM44: 0.3MPa, MXM54: 0.45MPa High temp. version (with rear casing cover): 0.7MPa

Pump identification

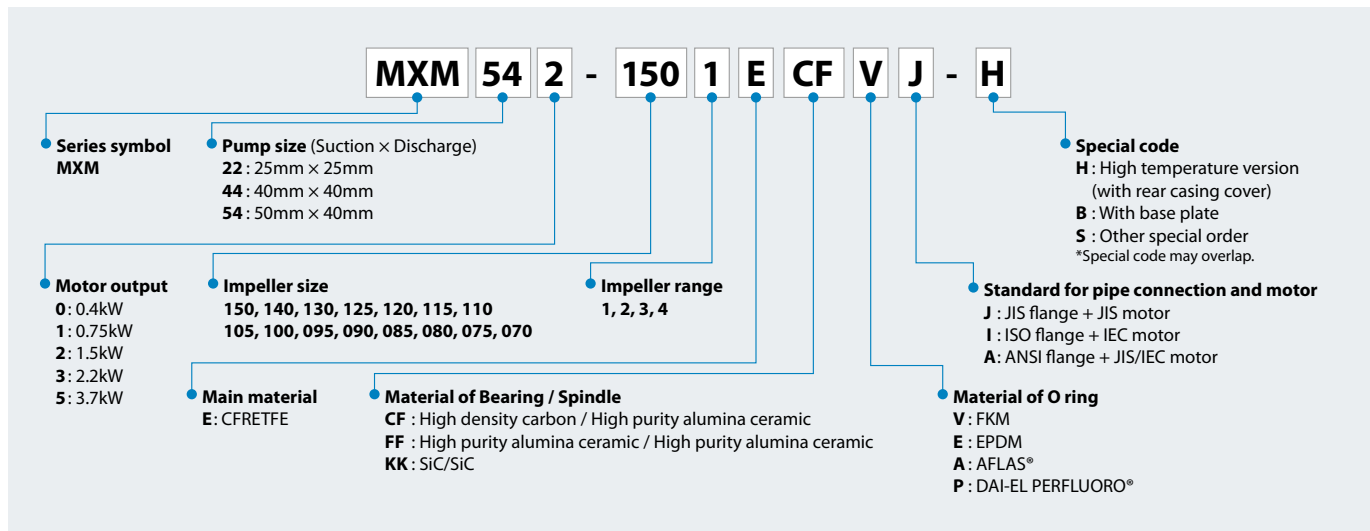

Notes for selection

(1) The performance curves in this catalogue represent the data measured using clear water at 20 °C.

(2) Choose the pump model suited to the liquid gravity.

Make sure that the motor output is at least five to ten percent higher than theoretically required.

$$\text{Shaft power (Sp)} \times \text{liquid gravity} \times 1.1 < \text{Motor output}$$

(Note) The shaft power (Sp) increases in proportion to the liquid gravity.

As the viscosity rises, the shaft power is higher while the head and the discharge are lower.
The power and the performance need to be adjusted.

(3) No magnetic drive pump supports continuous closed running. Be sure to ensure the minimum flow volume.

- Minimum flow volume
MXM22/44 : 10 L/min.
MXM54 Impeller range 1, 2 and 3 : 20 L/min.
Impeller range 4 : 50 L/min.

(4) The pressure resistance of the pump is as follows.

Be sure to ensure that the internal pressure of the pump does not exceed the value specified below.

- Standard model -10 °C to 90 °C (without rear casing cover)
MXM22: 0.2MPa, MXM44: 0.3MPa, MXM54: 0.45MPa
- High temperature version -10 °C to 105 °C (with rear casing cover)
: 0.7MPa

(5) FF material models

- Liquid should be 1m Pa-s (cP) or more.
- HQ performance is somewhat different from CF/KK models. If you need to know the detail, please contact with us.

(6) Deliberate prolonged dry running or entrained air operation is not recommended.

- The CF type has a degree of tolerance to dry running and operation with entrained air in the liquid.
- The KK type has the same degree of tolerance as the CF type under operation with entrained air in the liquid, but not allowed to run dry.
- The FF type is not allowed to run dry or operation with entrained air.

Performance curves

MXM22

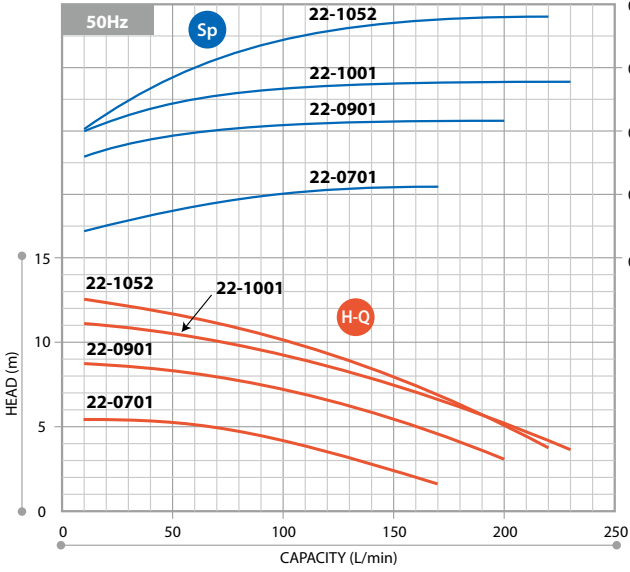

MXM44

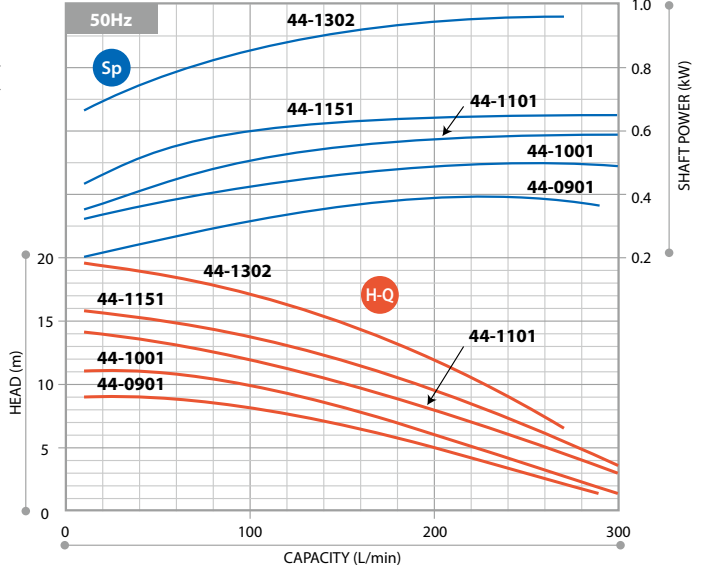

MXM54 Performance curves

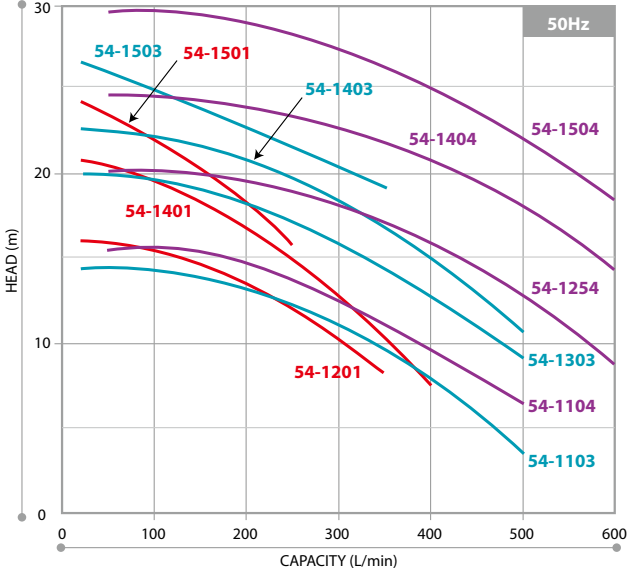

MXM54 (Impeller range 1)

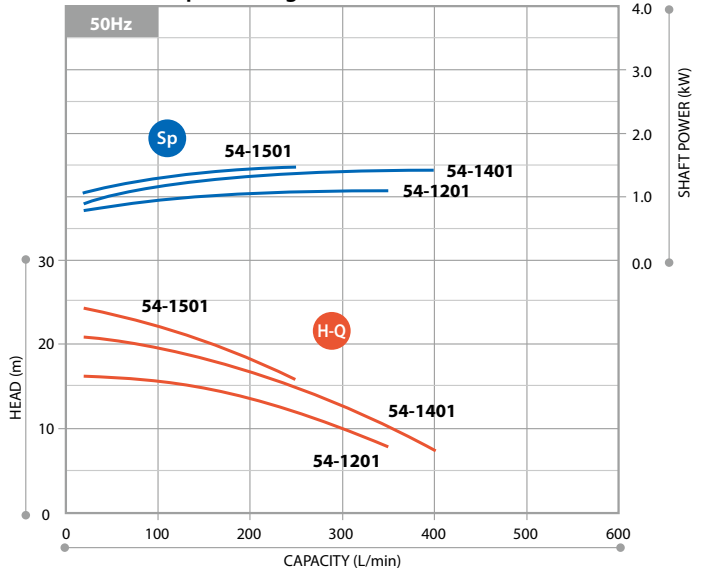

MXM54 (Impeller range 3)

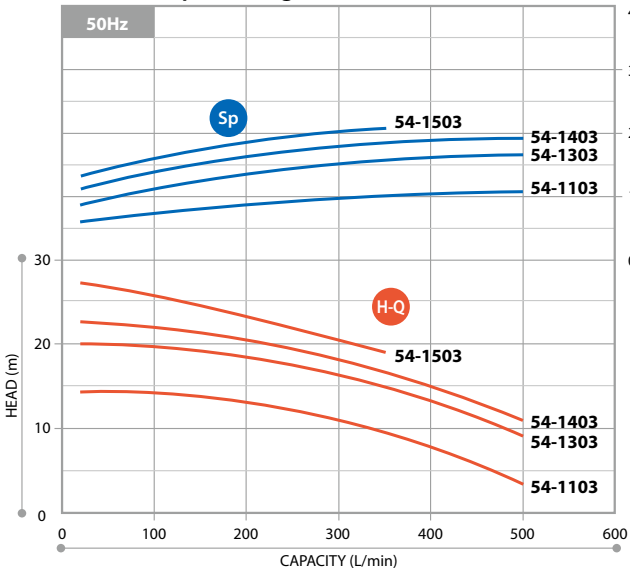

MXM54 (Impeller range 4)

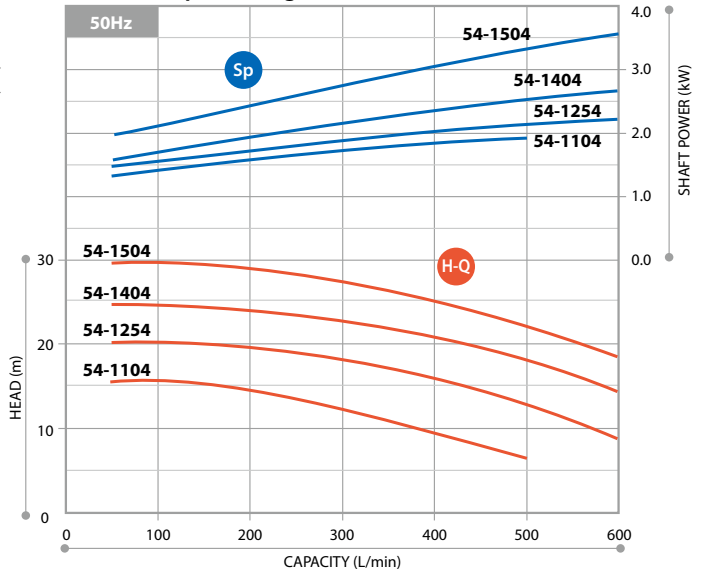

The shaft power curves shown above are calculated by using our standard test motor. Contact us for detail.

MXM22

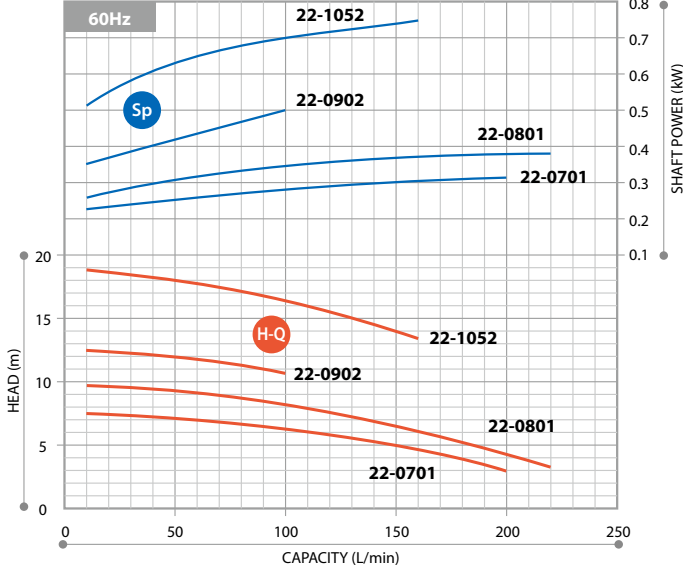

MXM44

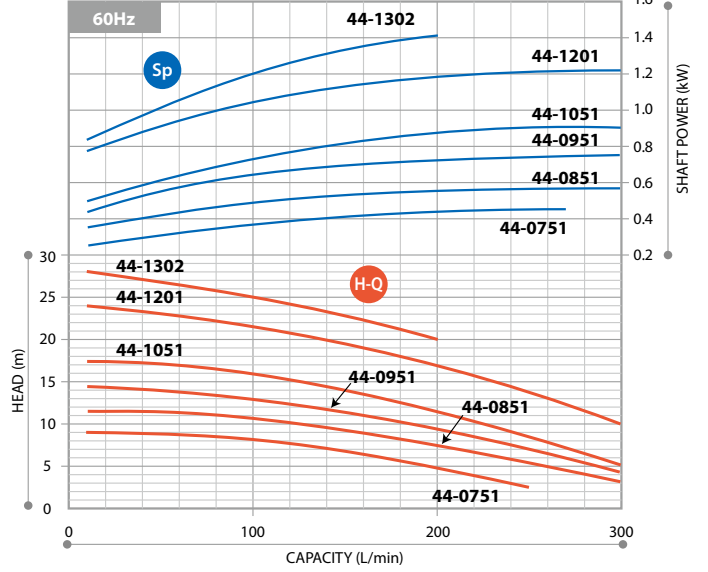

MXM54 Performance curves

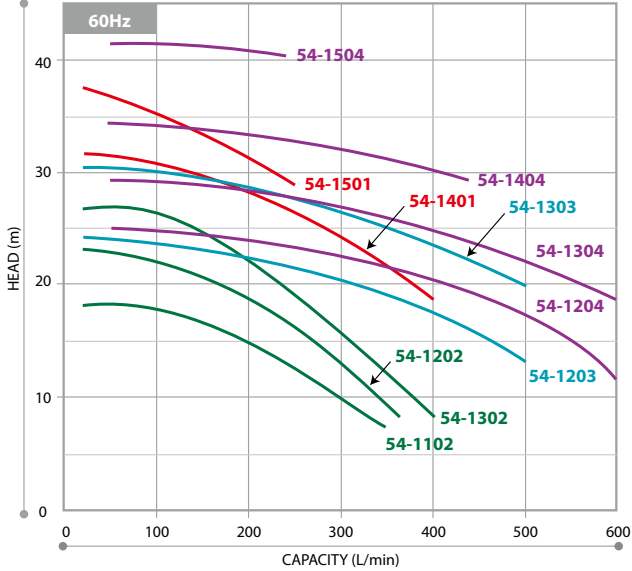

MXM54 (Impeller range 1, 2)

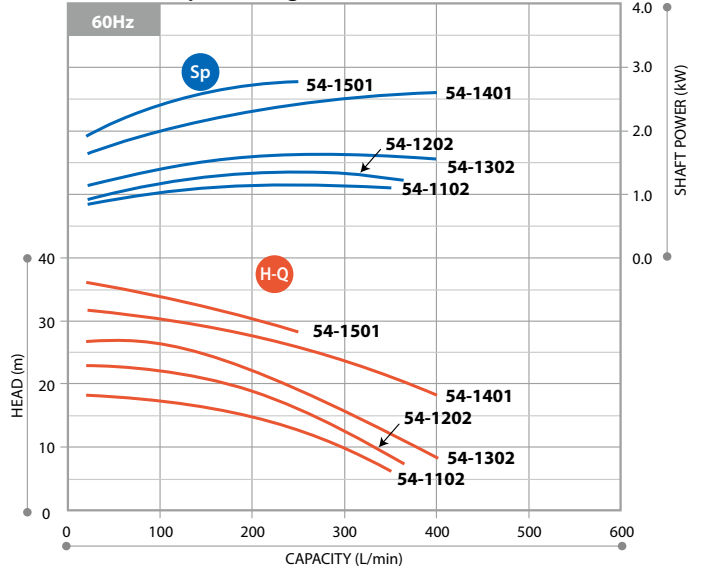

MXM54 (Impeller range 3)

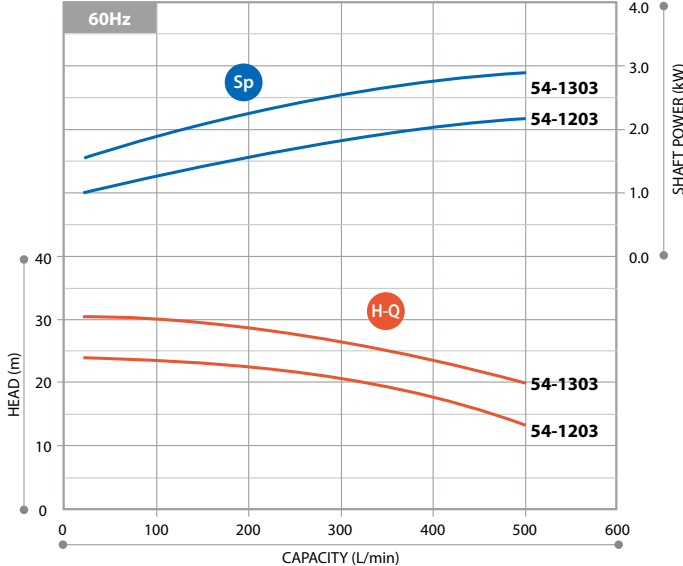

MXM54 (Impeller range 4)

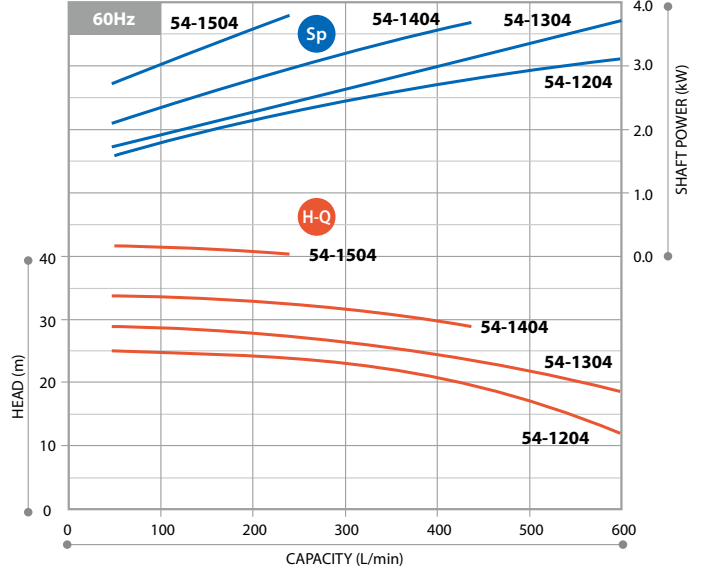

The shaft power curves shown above are calculated by using our standard test motor. Contact us for detail.

Dimensions in mm

Without base

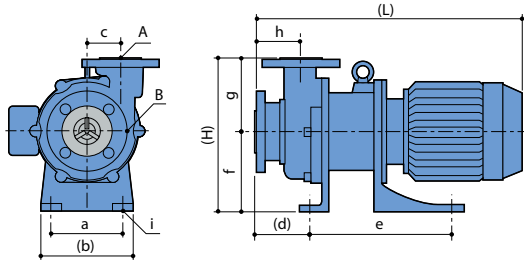

With base

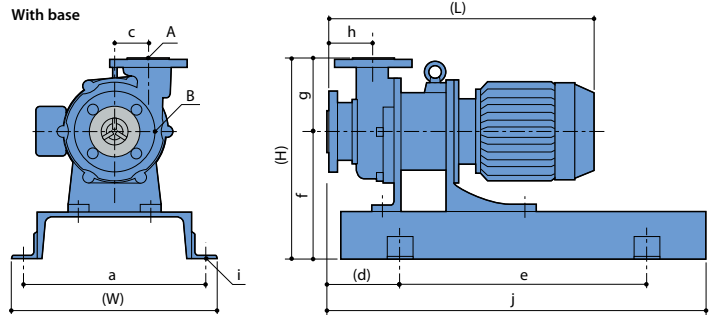

Without base

Model	(H)	(L)	A	B	a	(b)	c	(d)	e	f	g	h	i
MXM220	237	453	25A	25A	110	150	51	95	143	115	122	88	4-ø12
MXM220-H		475							165				
MXM221		467											
MXM221-H													
MXM441	275	482	40A	40A	130	170	58	113	250	135	140	106	4-ø14
MXM441-H		495											
MXM442		537											
MXM442-H													
MXM542	295	517	40A	50A	140	180	65	106	275	155	140	87	4-ø14
MXM543		589											
MXM545													

With base

Model	(W)	(H)	(L)	A	B	a	c	d	e	f	g	h	i	j
MXM220	300	317	453	25A	25A	250	51	130	220	195	122	88	4-ø19	450
MXM220-H			475											
MXM221			467											
MXM221-H														
MXM441	350	365	482	40A	40A	300	58	130	260	225	140	106	4-ø19	489
MXM441-H			495											
MXM442			537											
MXM442-H														
MXM542	400	385	517	40A	50A	350	65	140	480	245	140	87	4-ø19	735
MXM543			589											
MXM545														

Optional accessories

Iwaki dry running protector DR series

Model DR is electric current sensing type dry running protector. It detects the decreased load current (lower limit) to stop the pump when it runs dry or runs with air sucking in. It can detect over-load, too.



DR-20

- Current figure to be set is indicated on LCD.

- Both top/bottom figures can be set.

Top:Over-load

Bottom:Dry running, air sucking-in operation, operation with suction side closed

- Built-in current transformer

- DIN rail mounting

- It is unable to use DR when inverter is employed in the system.

Specification

50/60Hz

Model	DR-10	DR-20
Motor power	200 to 240V three phase	380 to 440V three phase
Applied motor	0.4 to 7.5kW	0.75 to 15kW
Power control	100 to 240V single phase	
Power	V	100V ±10%single phase
	Input	200 to 240V ±10%single phase
Detective current	3.5W	
Current transformer(CT)	0.5 to 32.0A	
Outer dimension in mm	Built-in	
	D80 X W153 X H122	

Note: The dry run protector can not be used along with inverter.

IWAKI CO., LTD. 6-6 Kanda-Sudacho 2-chome Chiyoda-ku Tokyo 101-8558 Japan TEL : (81)3 3254 2935 FAX : 3 3252 8892

www.iwaki-pumps.jp

EUROPE

European office : IWAKI Europe GmbH
 Holland : IWAKI Europe (NL Branch)
 Belgium : IWAKI Belgium N.V.
 Denmark : IWAKI Nordic A/S
 Finland : IWAKI Suomi Oy
 France : IWAKI France S.A.
 Germany : IWAKI Europe GmbH
 Italy : IWAKI Italia S.R.L.
 Norway : IWAKI Norge AS
 Spain : IWAKI Iberica Pumps, S.A.
 Sweden : IWAKI Sverige AB
 Switzerland : IWAKI (Schweiz) AG
 U.K. : IWAKI Pumps (UK) Ltd.

TEL: (49)2154 9254 0 FAX: 21 54 9254 48
 TEL: (31)547 293 160 FAX: 547 292 332
 TEL: (32)13 67 02 00 FAX: 13 67 20 30
 TEL: (45)48 24 2345 FAX: 48 24 2346
 TEL: (358)9 2745810 FAX: 9 2742715
 TEL: (33)1 69 63 33 70 FAX: 1 64 49 92 73
 TEL: (49)2154 9254 50 FAX: 21 54 9254 55
 TEL: (39)0444 371 115 FAX: 0444 335350
 TEL: (47)23 38 49 00 FAX: 23 38 49 01
 TEL: (34)943 630030 FAX: 943 628799
 TEL: (46)8 511 72900 FAX: 8 511 72922
 TEL: (41)26 674 93 00 FAX: 26 674 93 02
 TEL: (44)1743 231363 FAX: 1743 366507

ASIA / OCEANIA / NORTH AMERICA / SOUTH AMERICA

China : IWAKI Pumps Co., Ltd.
 Korea : IWAKI Korea Co., Ltd.
 Malaysia : IWAKIm Sdn. Bhd.
 Singapore : IWAKI Singapore Pte Ltd.
 Indonesia : IWAKI Singapore (Indonesia Branch)
 Taiwan : IWAKI Pumps Taiwan Co., Ltd.
 Thailand : IWAKI (Thailand) Co., Ltd.
 Vietnam : IWAKI Pumps Vietnam Co., Ltd.
 Australia : IWAKI Pumps Australia Pty Ltd.
 U.S.A. : IWAKI America Inc.
 Argentina : IWAKI America Inc. (Argentina Branch)

TEL: (852)2607 1168 FAX: 2607 1000
 TEL: (82)2 2630 4800 FAX: 2 2630 4801
 TEL: (60)3 7803 8807 FAX: 3 7803 4800
 TEL: (65)6316 2028 FAX: 6316 3221
 TEL: (62)21 6906606 FAX: 21 6906612
 TEL: (886)2 8227 6900 FAX: 2 8227 6818
 TEL: (66)2 322 2471 FAX: 2 322 2477
 TEL: (84)613 933456 FAX: 613 933399
 TEL: (61)2 9899 2411 FAX: 2 9899 2421
 TEL: (1)508 429 1440 FAX: 508 429 1386
 TEL: (54)11 4745 41 16

()Country codes

⚠ Caution for safety use: Before use of pump, read instruction manual carefully to use the product correctly. Actual pumps may differ from the photos. Specifications and dimensions are subject to change without prior notice. For further details please contact us.

⚠ Legal attention related to export.
 Our products and/or parts of products fall in the category of goods contained in control list of international regime for export control. Please be reminded that export license could be required when products are exported due to export control regulations of countries.

