



Construction

Close-coupled peripheral pump (regenerative pump) with turbine impeller. Compact, patented construction with single-piece motor casing and pump-side wall. Protected against water entering the motor from outside.

CT: version with pump casing in cast iron.

B-CT: version with pump casing in bronze (the pumps are supplied fully painted).

Applications

For clean liquids without abrasives, without suspended solids, non-explosive, non-aggressive for the pump materials. For increasing network pressure (follow local specifications). For the reduced dimensions, these pumps are very well suitable to be mounted in cooling and air-conditioning machines and equipments, circulation.

Operating conditions

Liquid temperature up to 60 °C.
Ambient temperature up to 40 °C.
Total suction lift up to 7 m.
Continuous duty.

Motor

2-pole induction motor, 50 Hz ($n \approx 2900$ rpm).

CT 61: three-phase 230/400 V $\pm 10\%$.

CTM 61: single-phase 230 V $\pm 10\%$, with thermal protector. Capacitor inside the terminal box.

Insulation class F.

Protection IP 54.

Constructed in accordance with: EN 60034-1;
EN 60335-1, EN 60335-2-41.

Special features on request

- Other voltages.
- Frequency 60 Hz (as per 60 Hz data sheet).
- Special mechanical seal.

Materials

| Components | CT 61 | B-CT 61 |
|-------------------------|------------------------------|------------------------------|
| Pump casing | Cast iron GJL 200 EN 1561 | Bronze G-Cu Sn 10 EN 1982 |
| Casing cover motor side | Brass P- Cu Zn Pb 2 UNI 5705 | |
| Impeller | Brass P- Cu Zn Pb 2 UNI 5705 | |
| Shaft | Chrome steel AISI 430 | |
| Mechanical seal | Carbon - Ceramic - NBR | |

Coverage chart $n \approx 2900$ rpm

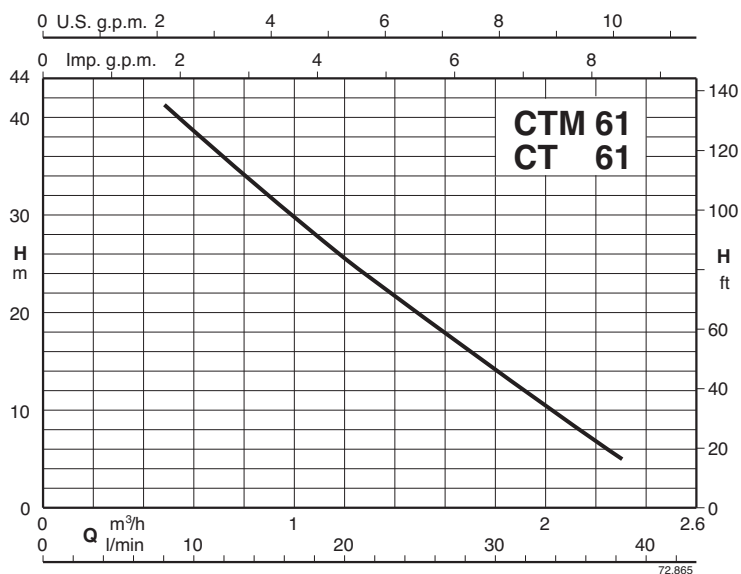

Performance $n \approx 2900$ rpm

| 3~ | 230V 400V | | 1~ | 230V | | P ₂ | | Q | | | | | | | |
|----------------|-----------|-----|-----------------|------|------|----------------|-------------------|------|------|------|------|------|-----|------|-----|
| | A | A | | A | kW | HP | m ³ /h | 0,48 | 0,6 | 0,75 | 0,96 | 1,2 | 1,5 | 1,89 | 2,3 |
| CT 61 | 1,9 | 1,1 | CTM 61 | 2,5 | 0,33 | 0,45 | H m | 41 | 38,5 | 35,5 | 31 | 25,5 | 19 | 11 | 3 |
| B-CT 61 | | | B-CTM 61 | | | | | | | | | | | | |

H Total head in m.

P₂ Rated motor power output.

Dimensions and weights

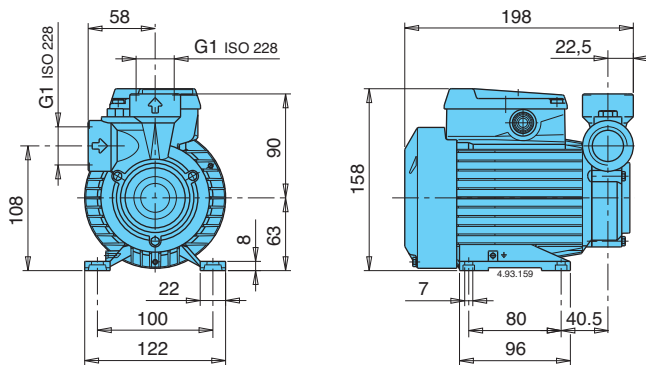

| | |
|----------|--------|
| CT 61 | 4,9 kg |
| CTM 61 | 5 kg |
| B-CT 61 | 5,1 kg |
| B-CTM 61 | 5,2 kg |

Features

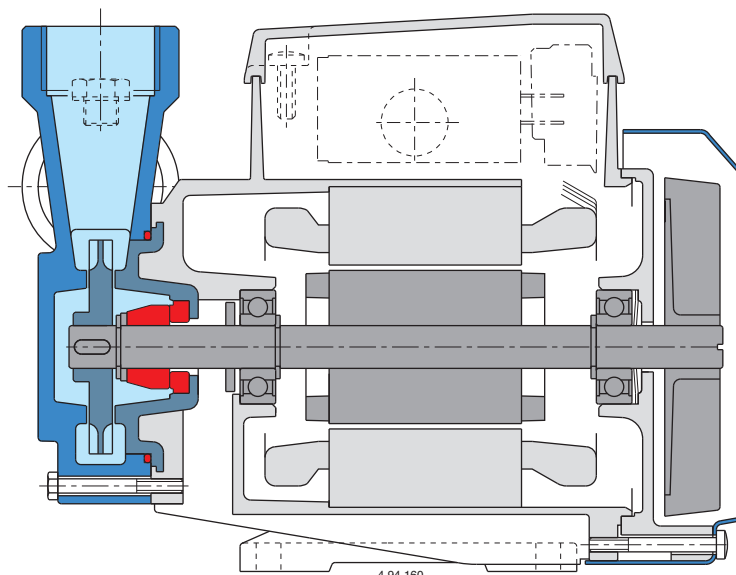



Construction

Close-coupled peripheral pump (regenerative pump) with turbine impeller.
 Compact, patented construction with single-piece motor casing and pump-side wall.
 Protected against water entering the motor from outside.

Applications

For clean liquids without abrasives, without suspended solids, non-explosive, non-aggressive for the pump materials.
 For increasing network pressure (follow local specifications).
 For the reduced dimensions, these pumps are very well suitable to be mounted in cooling and air-conditioning machines and equipments, circulation.

Operating conditions

Liquid temperature up to 60 °C.
 Ambient temperature up to 40 °C.
 Total suction lift up to 7 m.
 Continuous duty.

Motor

2-pole induction motor, 50 Hz ($n \approx 2900$ rpm).

CT 60: three-phase 230/400 V $\pm 10\%$.

CTM 60: single-phase 230 V $\pm 10\%$, with thermal protector.
 Capacitor inside the terminal box.

Insulation class F.

Protection IP 54.

Constructed in accordance with: EN 60034-1;
 EN 60335-1, EN 60335-2-41.

Materials

| Components | Materials |
|-------------------------|------------------------------|
| Pump casing | Cast iron GJL 200 EN 1561 |
| Casing cover motor side | Brass P- Cu Zn Pb 2 UNI 5705 |
| Impeller | Brass P- Cu Zn Pb 2 UNI 5705 |
| Shaft | Chrome steel AISI 430 |
| Mechanical seal | Carbon - Ceramic - NBR |

Special features on request

- Other voltages.
- Frequency 60 Hz (as per 60 Hz data sheet).
- Special mechanical seal.

Coverage chart $n \approx 2900$ rpm

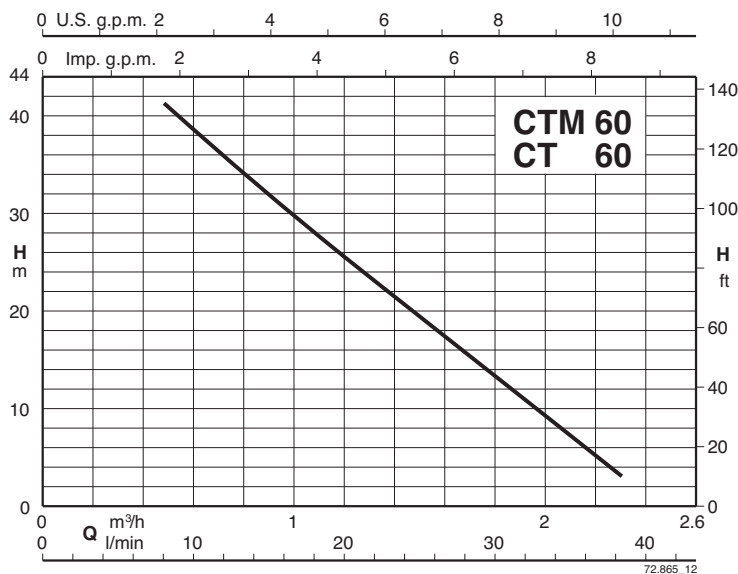

Performance $n \approx 2900$ rpm

| 3~ | 230V 400V | | 1~ | 230V | | P ₂ | | Q | | | | | | | | | |
|--------------|-----------|-----|---------------|------|------|----------------|-------------------|-------|------|------|------|------|-----|-----|------|-----|--|
| | A | A | | A | kW | HP | m ³ /h | l/min | 0,48 | 0,6 | 0,75 | 0,96 | 1,2 | 1,5 | 1,89 | 2,3 | |
| CT 60 | 1,9 | 1,1 | CTM 60 | 2,5 | 0,33 | 0,45 | H m | 41 | 38,5 | 35,5 | 31 | 25,5 | 19 | 11 | 3 | | |

H Total head in m.

P₂ Rated motor power output.

Dimensions and weights

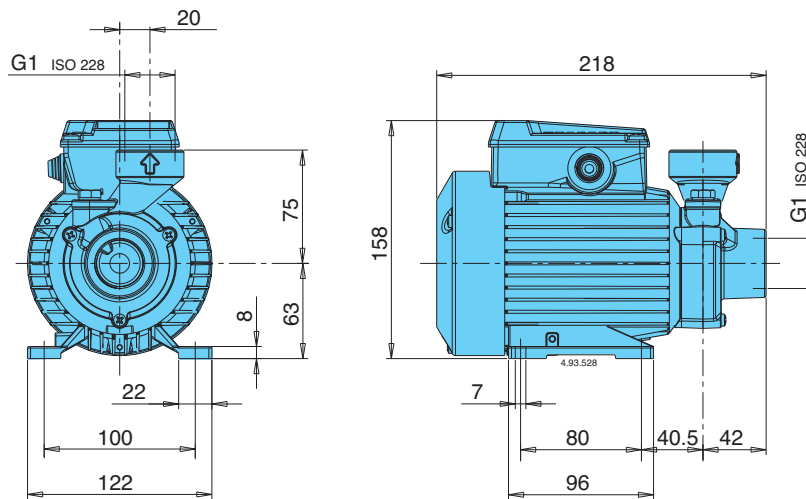

CT 60 4,9 kg
CTM 60 5 kg

Features

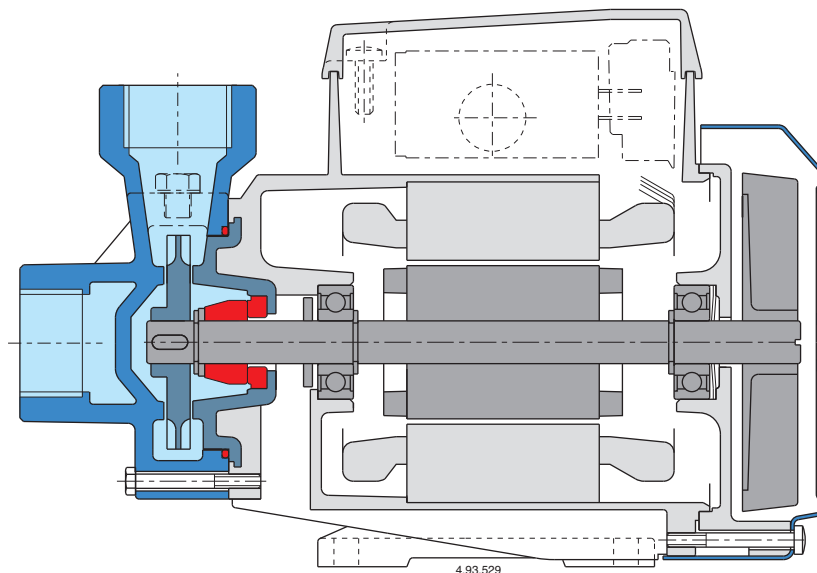

Patented



Construction

Close-coupled peripheral pumps (regenerative pumps) with turbine impeller.

T, TP: version with pump casing and lantern bracket in cast iron.
B-T, B-TP: version with pump casing and lantern bracket in bronze (the pumps are supplied fully painted).

Applications

For clean liquids without abrasives, without suspended solids, non-explosive, non-aggressive for the pump materials.
For increasing network pressure (follow local specifications).
For the reduced dimensions, these pumps are very well suitable to be mounted in cooling and air-conditioning machines and equipments, circulation, boiler feed.

Operating conditions

Liquid temperature from -10 °C to +90 °C.
Ambient temperature up to 40 °C.
Total suction lift up to 7 m.
Continuous duty.

Motor

2-pole induction motor, 50 Hz ($n \approx 2900$ rpm).

T, TP: three-phase 230/400 V $\pm 10\%$ up to 3 kW;
400/690 V $\pm 10\%$ from 4 to 7,5 kW;

TM, TPM: single-phase 230 V $\pm 10\%$ with thermal protector.
Capacitor inside the terminal box.

Insulation class F.

Protection IP 54.

Classification scheme IE2 for three-phase motors from 0,75 kW.
Constructed in accordance with: EN 60034-1; EN 60034-30.
EN 60335-1, EN 60335-2-41.

Special features on request

- Other voltages.
- Frequency 60 Hz (as per 60 Hz data sheet).
- Protection IP 55.
- Special mechanical seal.
- Higher or lower liquid or ambient temperatures.

Materials

| Components | T, TP | B-T, B-TP |
|-----------------|---|----------------------------|
| Pump casing | Cast iron | Bronze |
| Lantern bracket | GJL 200 EN 1561 | G-Cu Sn 10 EN 1982 |
| Casing cover | Cast iron | Bronze |
| | GJL 200 EN 1561 | G-Cu Sn 10 EN 1982 |
| | Brass P- Cu Zn Pb 40 2 UNI 5705 for T 61-65-70, B-T 61-70 | |
| Impeller | Brass P- Cu Zn 40 Pb 2 UNI 5705 | |
| | Bronze G-Cu Sn 10 EN 1982 for T 125, TP 132-132R | |
| Shaft | Cr-Ni steel AISI 303 T 76, Tp 80-100 | Cr-Ni-Mo steel AISI 316 |
| | Chrome steel AISI 430 T 61-65-70-100-125, Tp 78-132-132R | |
| Mechanical seal | Carbon - Ceramic - NBR | |

Coverage chart $n \approx 2900$ rpm

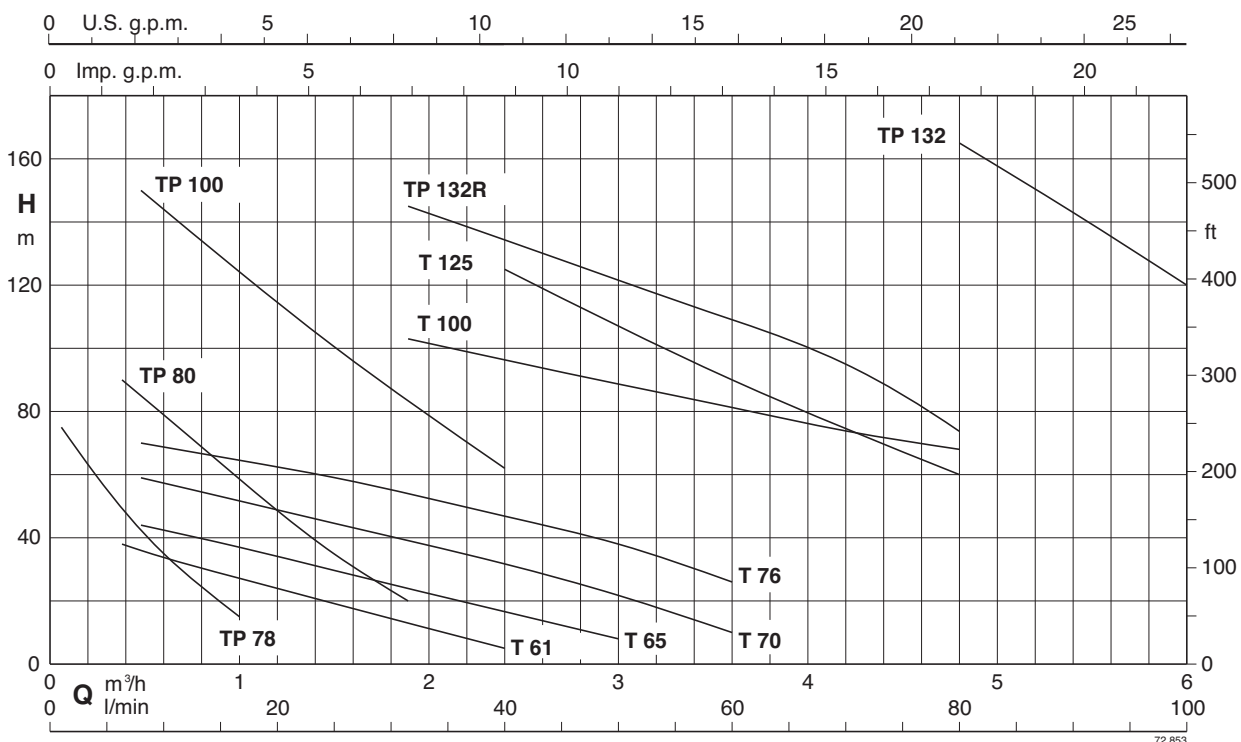

Performance $n \approx 2900$ rpm

| | 3 ~ 230V 400V | | 1 ~ 230V | P ₁ | | P ₂ | | Q m ³ /h l/min | H m | | | | | | | | | | | | | | | | | |
|-----------|---------------|------|------------|----------------|------|----------------|------|---------------------------------|--------|------|------|------|------|-----|------|-----|-----|-----|------|-----|-----|-----|-----|-----|-----|---------------|
| | A | A | | A | kW | kW | HP | | 0,06 | 0,12 | 0,24 | 0,38 | 0,48 | 0,6 | 0,75 | 1 | 1,2 | 1,5 | 1,89 | 2,4 | 3 | 3,6 | 4,2 | 4,8 | 5,4 | 6 |
| B-T 61E | 1,9 | 1,1 | B-TM 61E | 2,5 | 0,55 | 0,33 | 0,45 | | 1 | 2 | 4 | 6,3 | 8 | 10 | 12,5 | 16 | 20 | 25 | 31,5 | 40 | 50 | 60 | 70 | 80 | 90 | 100 |
| B-T 65E | 2,8 | 1,6 | B-TM 65E | 3,5 | 0,8 | 0,45 | 0,6 | | | | | 38 | 36 | 34 | 31,5 | 28 | 24 | 19 | 12,5 | 5 | | | | | | |
| B-T 70/A | 3,7 | 2,2 | B-TM 70/A | 6 | 1,3 | 0,75 | 1 | | | | | 44 | 42 | 40 | 37 | 33 | 29 | 24 | 16 | 8 | | | | | | |
| T 76E | 5,3 | 3 | TM 76E | 7,4 | 1,6 | 1,1 | 1,5 | | | | | 59 | 57 | 55 | 51 | 48 | 43 | 38 | 30 | 22 | 10 | | | | | |
| T 100/A | 11,5 | 6,6 | | | | 3 | 4 | | | | | 70 | 68 | 67 | 65 | 62 | 58 | 53 | 46 | 38 | 26 | | | | | |
| T 125/A | | 9,6 | | | | 4 | 5,5 | | | | | | | | | | | 103 | 97 | 89 | 82 | 75 | 68 | | | |
| B-TP 78/A | 2,3 | 1,3 | B-TPM 78/A | 2,8 | 0,6 | 0,37 | 0,5 | | 75 | 70 | 60 | 50 | 42 | 35 | 25 | 15 | | | 125 | 110 | 90 | 75* | 60* | | | |
| B-TP 80E | 3,3 | 1,9 | B-TPM 80E | 5,8 | 1,2 | 0,75 | 1 | | | | | 90 | 85 | 79 | 73 | 61 | 48 | 34 | 20 | | | | | | | |
| TP 100/A | 9,6 | 5,5 | | | | 2,2 | 3 | | | | | 160 | 157 | 151 | 140 | 129 | 115 | 99 | 82 | | | | | | | |
| TP 132R/A | | 10,9 | | | | 5,5 | 7,5 | | | | | | | | | | | 145 | 135 | 120 | 110 | 95 | 70 | | | |
| TP 132/A | | 14,3 | | | | 7,5 | 10 | | | | | | | | | | | | | | | | | | | 165 143* 120* |

P1 Maximum power input.

B-T, B-TM = Bronze construction.

H Total head in m.

* Maximum suction lift 2-3 m.

P2 Rated motor power output.

Dimensions and weights

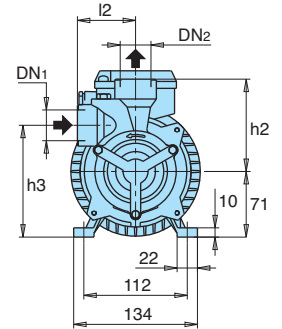
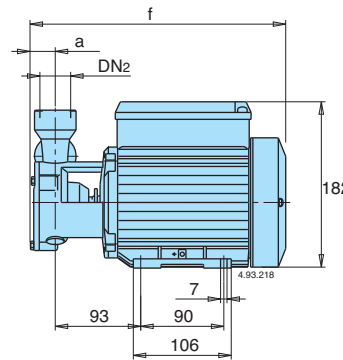
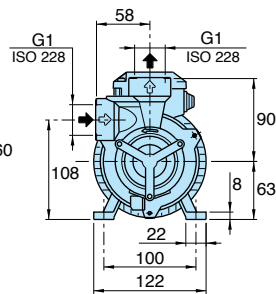
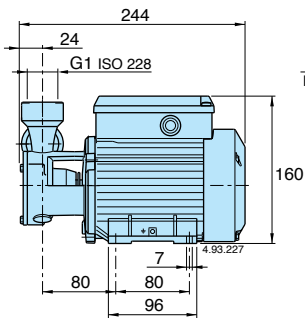

- T 61E: kg 6,3
- B-T 61E: kg 6,5
- T 65E: kg 7,3
- B-T 65 : kg 7,5

| TYPE | DN1 ISO 228 | DN2 ISO 228 | mm | | | | | kg | |
|-------------------|----------------|----------------|----|-----|-----|-----|----|------|------|
| | | | a | f | h2 | h3 | l2 | T | B-T |
| T 70/A B-T 70/A | G 1 | G 1 | 24 | 278 | 100 | 121 | 63 | 11,2 | 11,6 |
| TP 78/A B-TP 78/A | G 1/2 | G 1/2 | 22 | 276 | 80 | 127 | 56 | 8,2 | 8,8 |

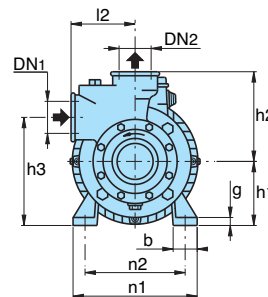
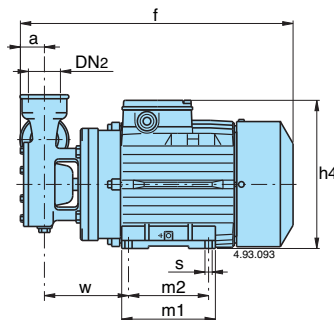

| TYPE | DN1 ISO 228 | DN2 ISO 228 | mm | | | | | | | | | | | | | | kg | | | |
|-----------------|----------------|----------------|----|-----|-----|-----|-----|-----|-----|-----|-----|-----|----|------|----|-----|-----|----|-------|------|
| | | | a | f | h1 | h2 | h3 | h4 | m1 | m2 | n1 | n2 | b | s | l1 | l2 | w | g | T, TP | B-TP |
| T 76E | G 1 1/4 | G 1 1/4 | 26 | 338 | 80 | 112 | 136 | 203 | 117 | 100 | 155 | 125 | 30 | 9 | - | 80 | 105 | 10 | 18,4 | - |
| T 100/A | G 1 1/4 | G 1 1/4 | 32 | 410 | 90 | 130 | 161 | 226 | 152 | 125 | 180 | 140 | 40 | 9,5 | - | 95 | 121 | 12 | 32,5 | - |
| T 125/A | G 1 1/4 | G 1 1/4 | 32 | 470 | 90 | 155 | 170 | 226 | 152 | 125 | 180 | 140 | 40 | 9,5 | - | 90 | 195 | 12 | 39,5 | - |
| TP 80E B-TP 80E | G 3/4 | G 3/4 | 27 | 332 | 80 | 90 | 135 | 203 | 117 | 100 | 155 | 125 | 30 | 9 | - | 60 | 104 | 10 | 16,4 | 16,8 |
| TP 100/A | G 3/4 | G 3/4 | 27 | 387 | 80 | 100 | 142 | 203 | 117 | 100 | 155 | 125 | 30 | 9 | - | 65 | 113 | 10 | 23,2 | - |
| TP 132R/A | G 1 1/4 | G 1 1/4 | 42 | 485 | 112 | 160 | 202 | 272 | 180 | 140 | 230 | 190 | 50 | 11,5 | - | 100 | 183 | 14 | 53,6 | - |
| TP 132/A | G 1 1/4 | G 1 1/4 | 42 | 485 | 112 | 160 | 202 | 272 | 180 | 140 | 230 | 190 | 50 | 11,5 | - | 100 | 183 | 14 | 58,5 | - |

Characteristic curves $n \approx 2900$ rpm

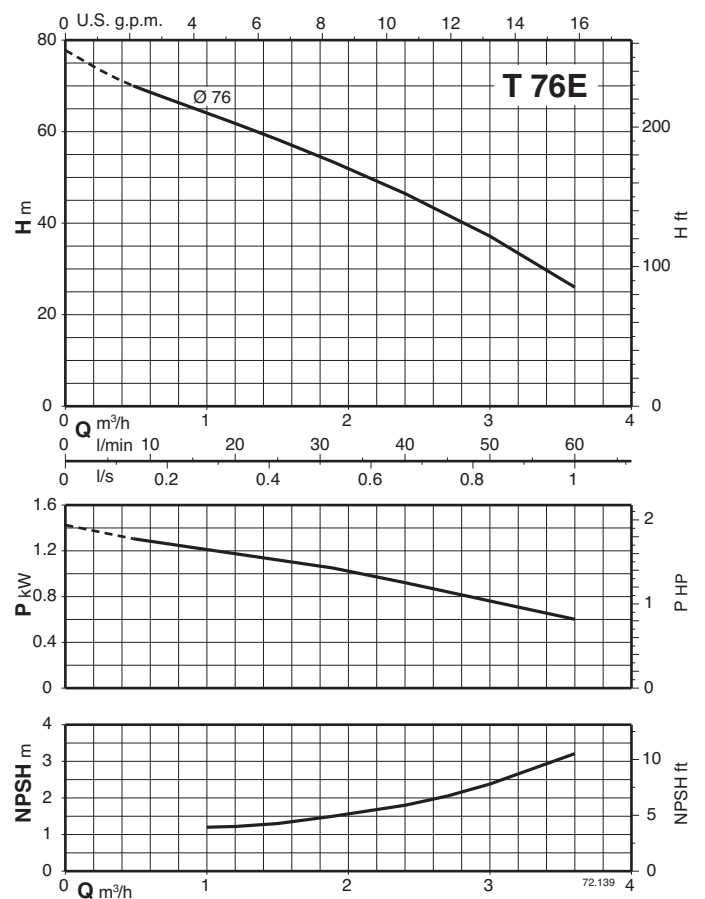
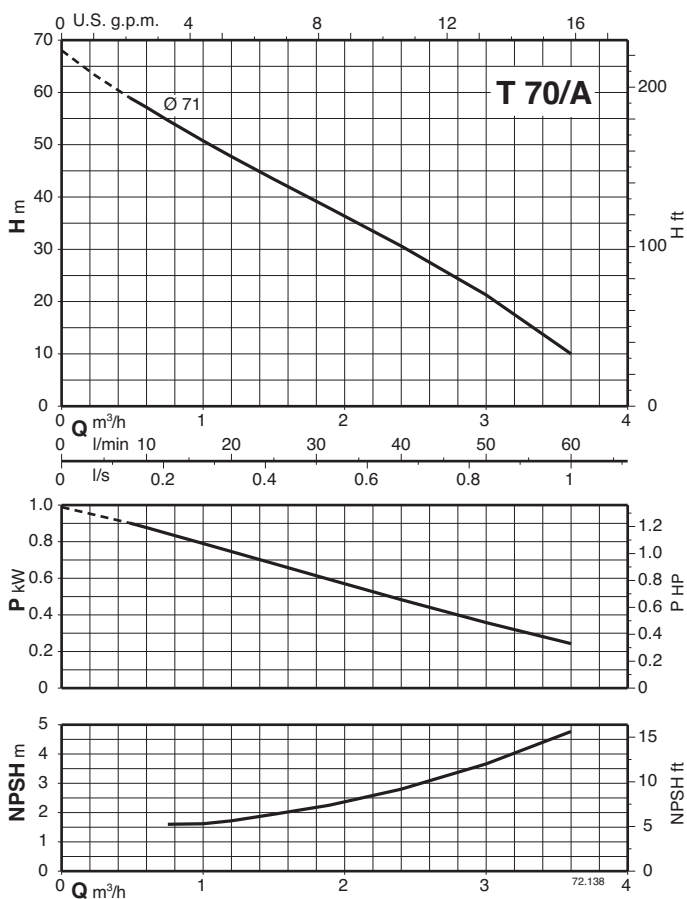
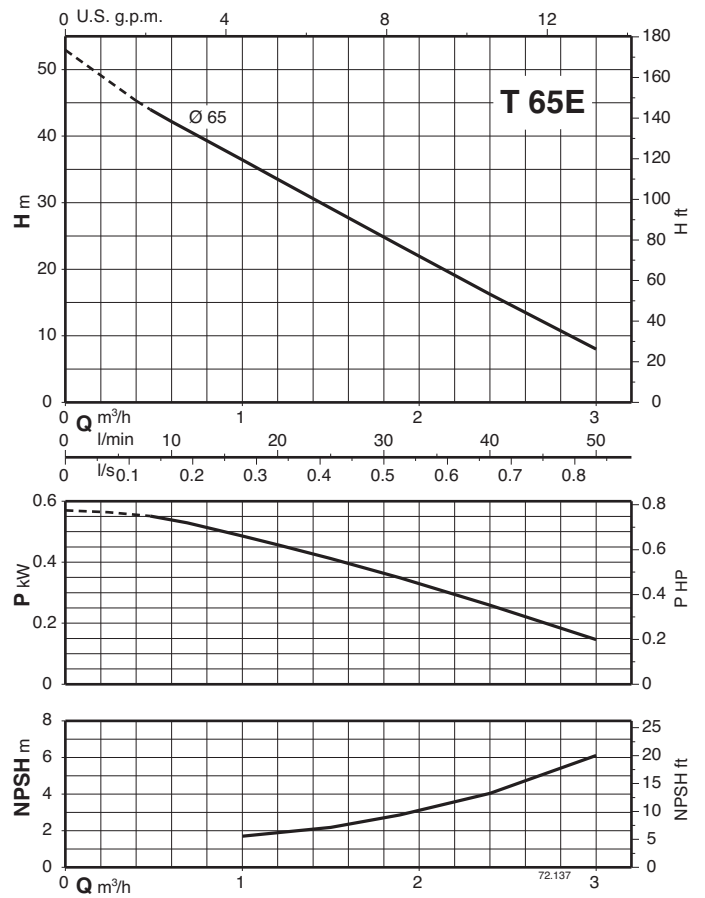
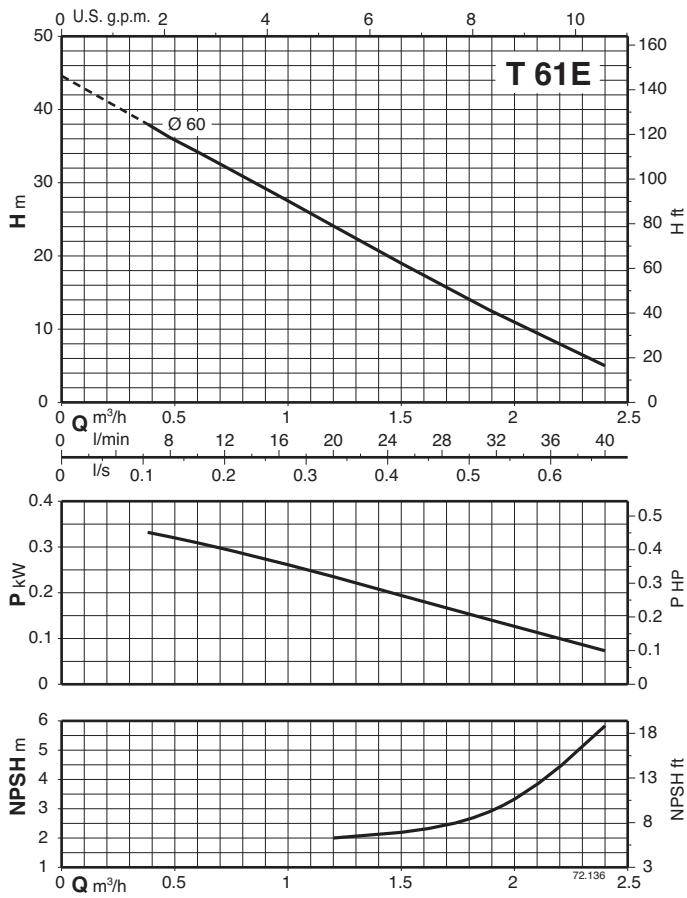

Characteristic curves $n \approx 2900$ rpm

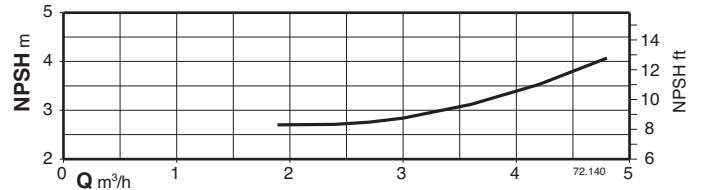
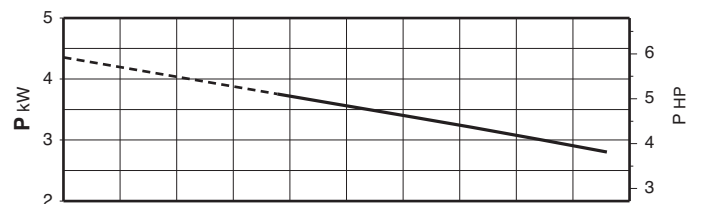
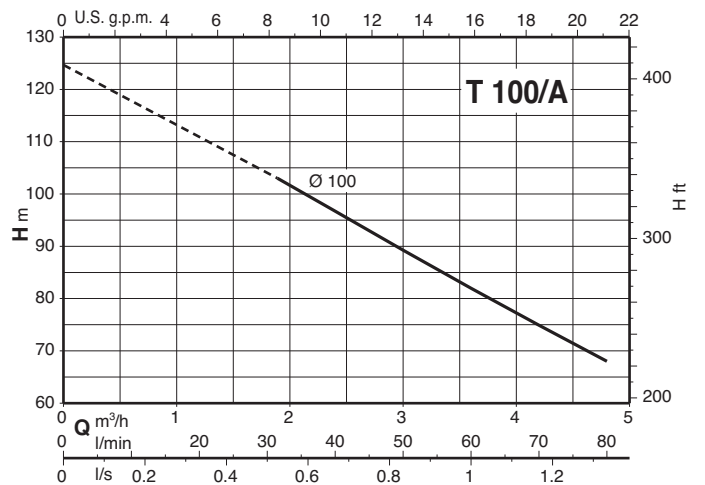
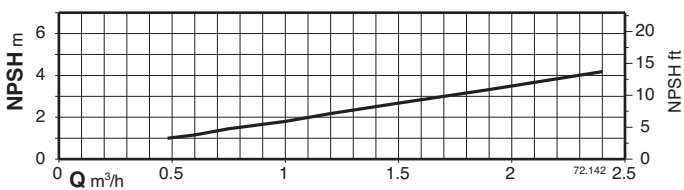
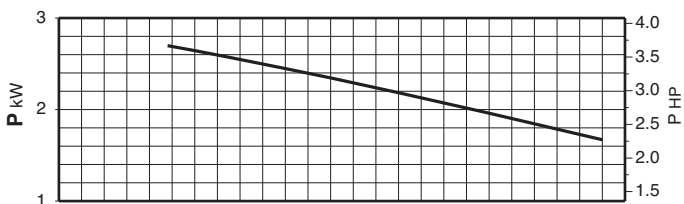
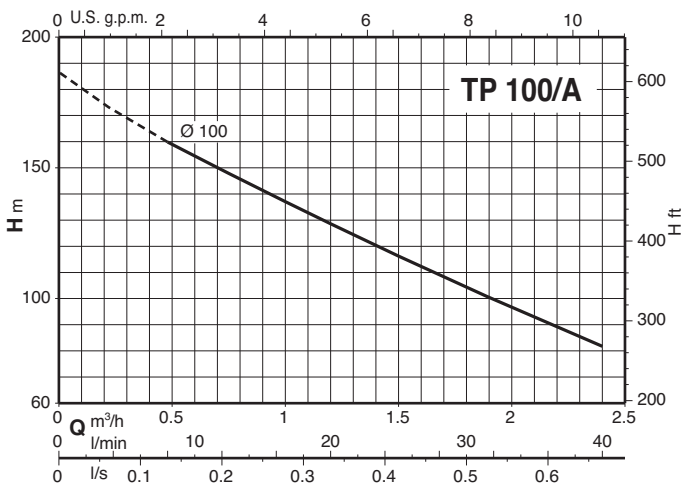
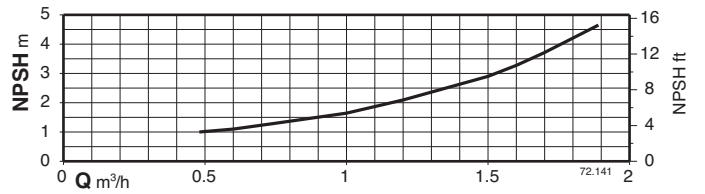
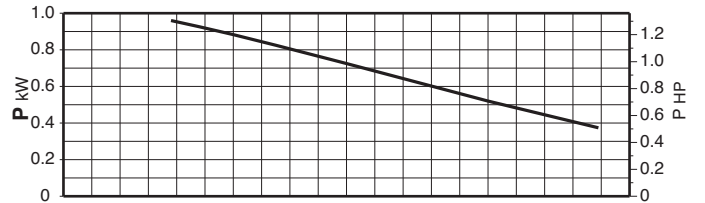
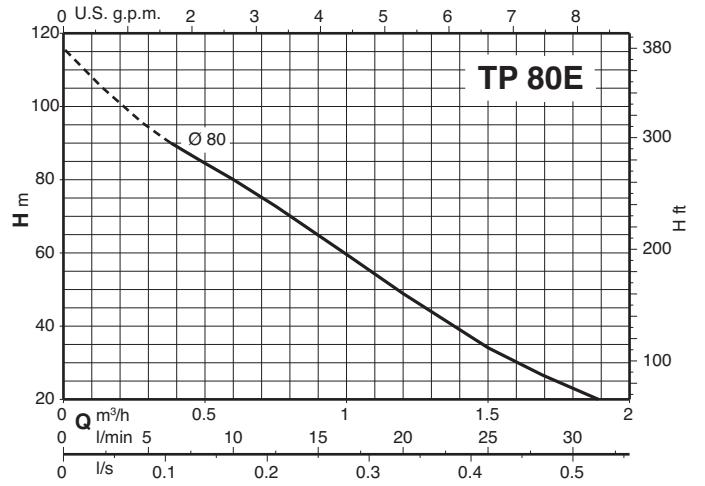
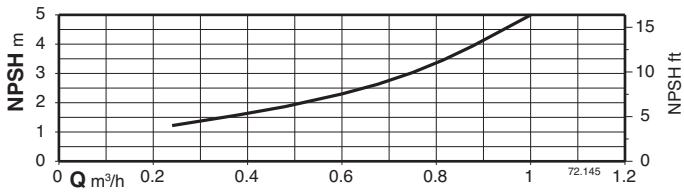
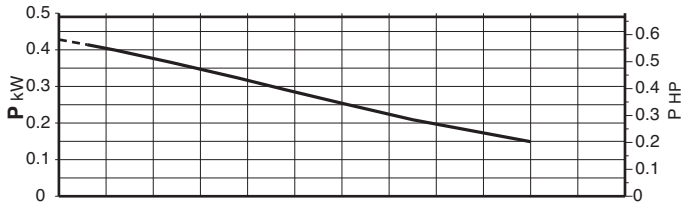
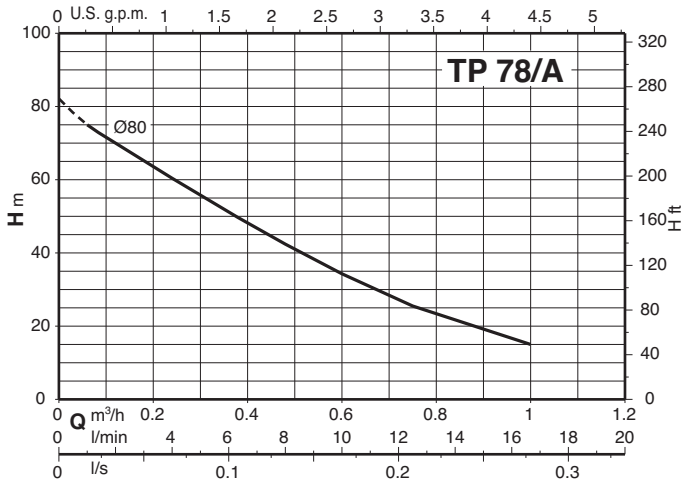

Characteristic curves $n \approx 2900$ rpm

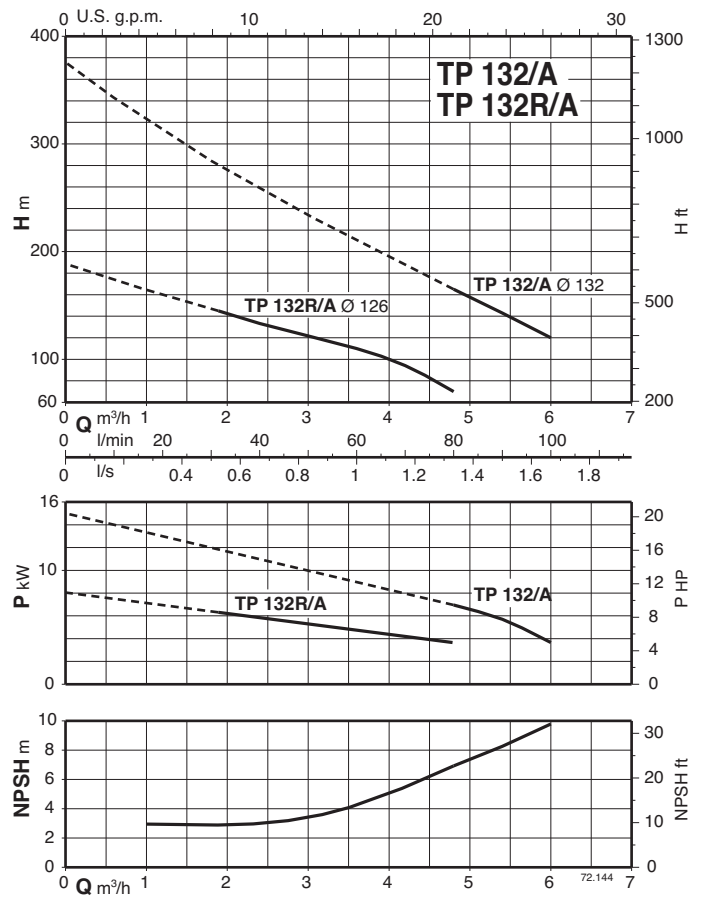
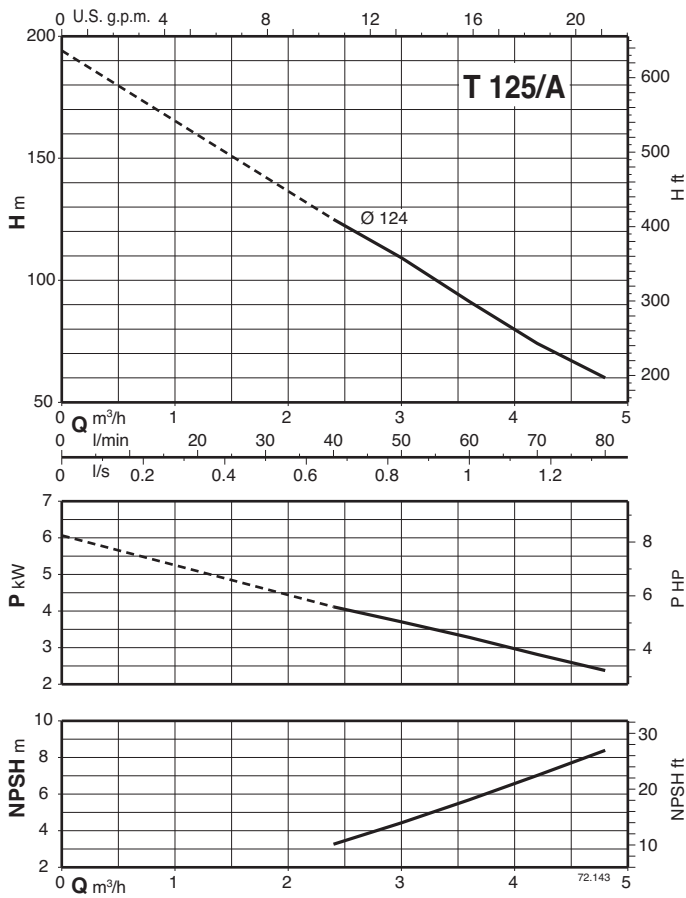

Features

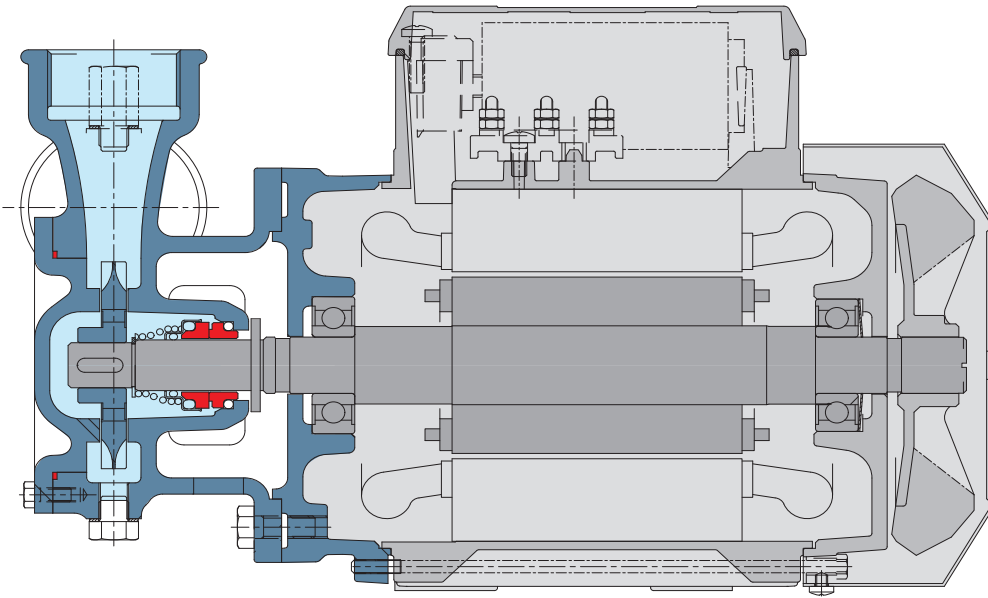

Range

The high number of pumps in the range can meet the widest range of services required by the user.

Flexible

The option to choose between cast iron and bronze materials for the hydraulic parts in contact with the pumped liquid allows T-TP series pumps to be selected for use with different types of liquids.

Reliable

The bearing and shaft are designed to ensure the reduction of the stress, providing high reliability under all operating conditions.

Optimized hydraulics

The pump hydraulics are designed to ensure high performance and consistency of performance.