



JMI Submersible Motor Pumps



JMI J.M.I Co., LTD



INTRODUCTION

As an international manufacturer leader of submersible pumps, mixers and related accessories, **JMI** has been producing comprehensive products that range from building services to industrial process such as waster water and raw material treatment, protection of flood and heavy rain etc.

Since JMI was founded, our products have gotten a good reputation throughout the world for its high quality and pumping systems. With KS, ISO 9001 & ISO 14001 certified, JMI is concentrating on developing the new technology in order to provide maximum customer satisfaction.

JMI will continue to grow and develop at a rapid speed and we will be one of the best manufactures in this field.

Whenever and wherever the customers are, we are always there to help.

- J.M.I Co., Ltd -





JMI Submersible Motor Pumps





Submersible Motor Pumps

Application



Supplying Hot Water

- various hydraulic circulation pump
- circulation of heated water or cool water at home



Supplying water and Pressure

- transfer/press hot water, cool water at the building, plant, fire fighting system



Generator and Refining

- circulation pump of cooling water
- transfer wastewater

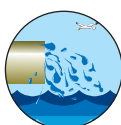

Sewage, Wastewater, Rain

- drainage pump at underground, construction, swimming pool, farm
- supplying the Oxygen of waste and sewage treatment plant
- protection of flood



Beverage and Drinking Water

- transfer beverage, drinking water
- supplying underground water



Hot spring, Gardening, Irrigation Water

- supplying the water at hot spring, gardening, irrigation water
- irrigation pump for stream, dam, reservoir



Food

- transfer/supplying food material
- homogenize the liquid



Pulp and Paper

- transfer liquid containing sludge at pulp and paper plant
- vacuum pump for dehydration



Sewage and Chemical

- transfer sewage and waste water at chemical plant, hospital, laboratory

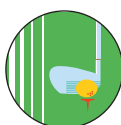

Golf Link

- supplying the water at a golf link



Mine and Iron mill

- pumping/transfer at mine, Iron mill



Industry

- transfer/pressure/circulation pump of various hydraulic and hot water, cool water at a industrial site
- be able to apply to various process

PRODUCT ABILITY

- Discharge diameter : 40 - 2000[MM]
- Power : 0.75 - 1000[KW]
- Capacity : 0.05 - 500[m³/min]
- Frequency : 50/60HZ
- Voltage : 110 - 3300[V]
- Poles : 2 - 24Pole

MODEL NUMBER DESIGNATION

500 JPS 75 10 T3

- Discharge diameter : 500[MM]
- Manufacturer: J.M.I Co., LTD.
- Pump Type : P(Propeller Pump), D(Drainage), S(Sewage), W(Wastewater), M(Mixed flow), X(Mixer), R(Aerator), A(Aquarator), G(Gravel), SV(Semi-Vortex), V(Vortex)
- Motor Power : 75[KW]
- Number of Poles : 10[P]
- Phase : Single(S), 3Phase(T), Voltage : 220(V), 380(V), 440(V), 3300(V)



Submersible Motor Pumps



JPSV Vortex pump for sewage and wastewater treatment



- Motor**
 - 2 pole
 - Insulation Class : F
 - 3Phase/220V/380V/440V
 - 3000rpm
 - Line Start
 - Standard Power : 0.75KW~15KW
- Pump**
 - Impeller : Semi-vortex type
 - Material
 - Impeller : FC200/SCS13
 - Casing : FC200/SCS13
 - Shaft : SCM440/SUS410
 - Connecting method
 - Flange Coupling/Hose Coupling/ Automatic Discharge connector

- Application**
 - Transport of sludge at farm, hotel, hospital, restaurant
 - Transport of sewage from septic tank
 - Transport of the raw source from wastewater treatment plant



- Features**
 - Easy to maintain with Automatic Discharge Connector
 - Easy to transfer solid with Semi-vortex
 - Equipped electric motor protector
 - High head

Drawing

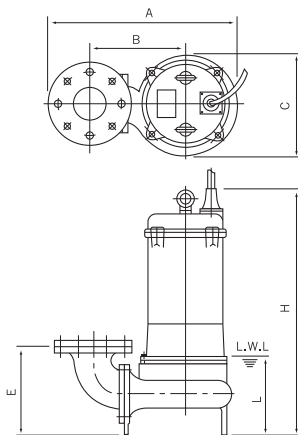

Performance curve

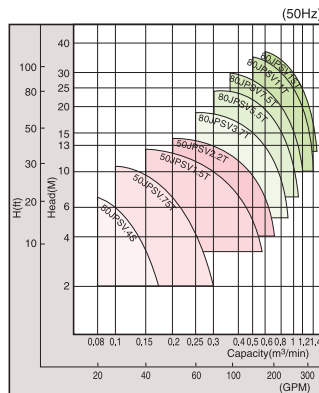

Standard model

Discharge (mm)	MODEL	Output (Kw)	Head (M)	Capacity (m³/min)	A (mm)	B (mm)	C (mm)	E (mm)	H (mm)	L (mm)	Weight (Kg)
50	50JPSV0.4S	0.4	6	0.1	250	125	170	99	400	96	19
	50JPSV0.75S	0.75	7	0.20	250	127	170	99	420	96	24
	50JPSV0.75T	0.75	7	0.20	360	200	185	180	420	150	30
	50JPSV1.5T	1.5	10	0.30	380	210	210	175	500	200	55
	50JPSV2.2T	2.2	10	0.46	380	210	210	175	500	200	65
80	80JPSV3.7T	3.7	15	0.50	510	280	260	215	620	300	75
	80JPSV5.5T	5.5	18	0.46	510	280	260	215	670	300	100
	80JPSV7.5T	7.5	20	0.50	540	310	295	210	780	350	160
	80JPSV11T	11	25	1.0	540	310	295	210	830	350	185
	80JPSV15T	15	30	1.0	675	390	370	240	920	400	195

JPV Vortex pump for sewage and wastewater treatment



- Motor**
 - 4 pole
 - Insulation Class : F
 - 3Phase/220V/380V/440V
 - 1500rpm
 - Line Start
 - Standard Power : 2.2KW~15KW
- Pump**
 - Impeller : Vortex Type
 - Material
 - Impeller : FC200/SCS13
 - Casing : FC200/SCS13
 - Shaft : SCM440/SUS410
 - Connecting method
 - Flange Coupling/Hose Coupling/ Automatic Discharge connector

- Application**
 - Transport of sludge at farm, hotel, hospital, restaurant
 - Transport of sewage from septic tank
 - Transport of the raw source from wastewater treatment plant



- Features**
 - Increase the duality of motor with 4 pole
 - Transport of solid particle size up to maximum 80mm with vortex structure
 - Easy to maintain with Automatic Discharge Connector
 - Equipped with the electric motor protector
 - Perfect watertight with double mechanical seal

Drawing

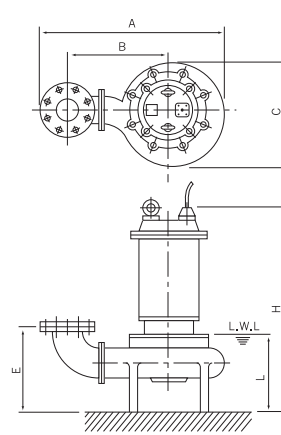

Performance curve

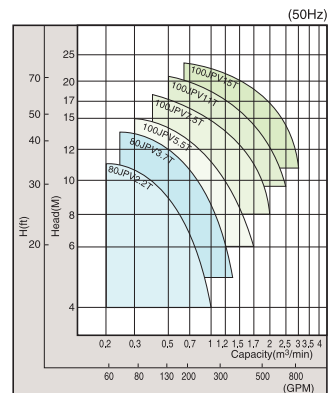

Standard model

Discharge (mm)	MODEL	Output (Kw)	Head (M)	Capacity (m³/min)	A (mm)	B (mm)	C (mm)	E (mm)	H (mm)	L (mm)	Weight (Kg)
80	80JPV2.2T	2.2	9	0.5	530	290	280	230	600	230	56
	80JPV3.7T	3.7	10	0.8	530	290	280	230	670	230	64
100	100JPV5.5T	5.5	10	1.2	620	350	350	290	825	260	121
	100JPV7.5T	7.5	14	1.2	620	350	350	290	825	260	133
	100JPV11T	11	16	1.5	620	350	350	290	940	270	170
	100JPV15T	15	18	1.8	620	350	350	290	940	270	200

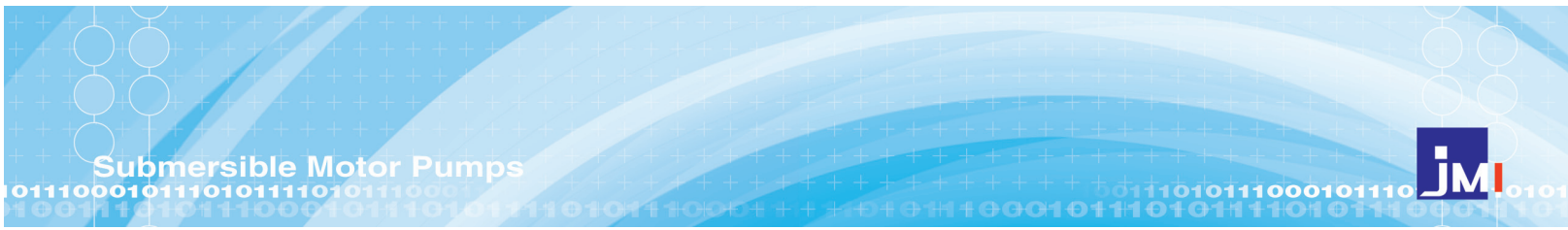

Submersible Motor Pumps

JPS

For sewage and wastewater treatment

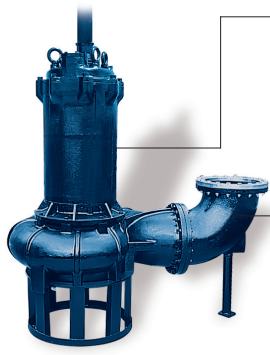

- **Motor**
 - 2~14 pole
 - Insulation Class : F
 - 3Phase/220V/380V/440V
 - 3000~429rpm
 - Line Start(0.75KW~15KW)
 - Star Delta(15KW~110KW)
 - Standard Power : 22KW~190KW
- **Pump**
 - Impeller : Enclosed type
 - Material
 - Impeller : FC200/SCS13
 - Casing : FC200/SCS13
 - Suction Cover : FC200/SCS13
 - Shaft : SCM440/SUS410
 - Connecting method
 - Flange Coupling/Hose Coupling/
 - Automatic Discharge connector

- **Application**
 - Transfer solid at sewage, wastewater treatment plant
 - Effluent transfer from waste & sewage water treatment plant
 - Fountain, decorative waterfall
 - Supply factory with industrial water



- **Features**
 - Minimizing stopping-up of foreign materials
 - Multi-pole applicable according to water quantity
 - Increase durability with 4 pole motor
 - Including the electric motor protector
 - Perfect watertight with double mechanical seal

Performance curve

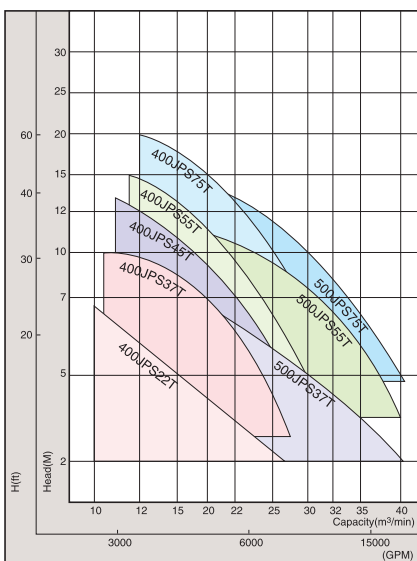
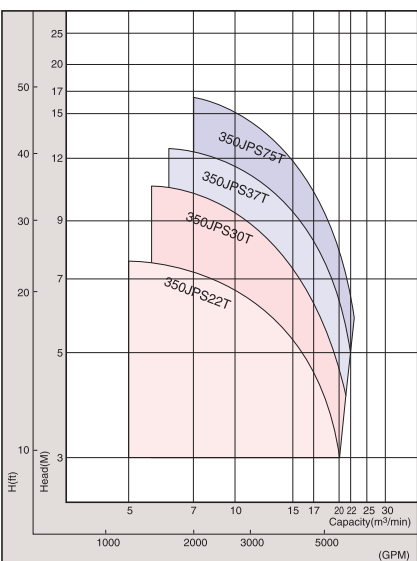
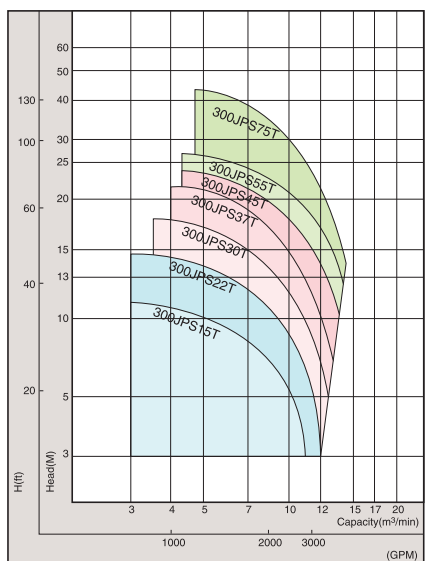
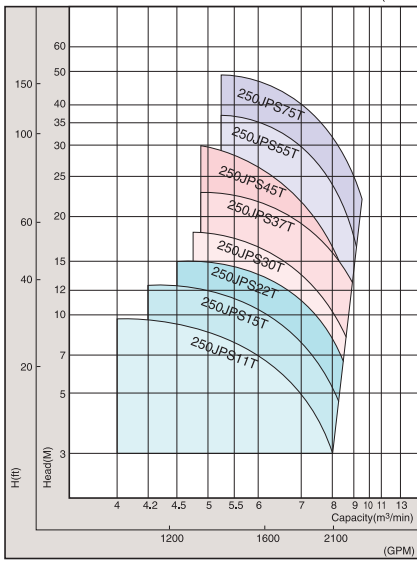
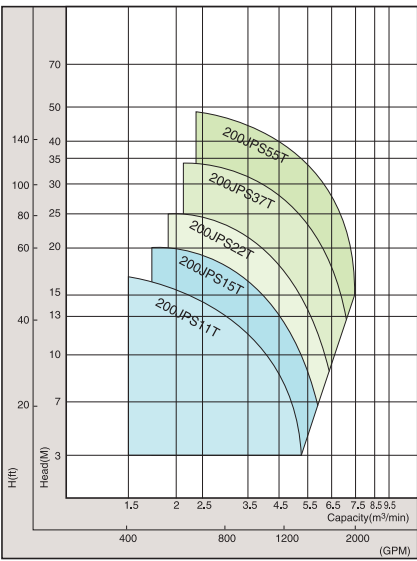
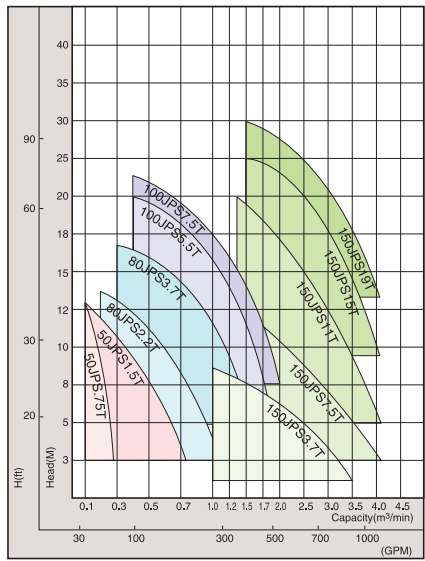

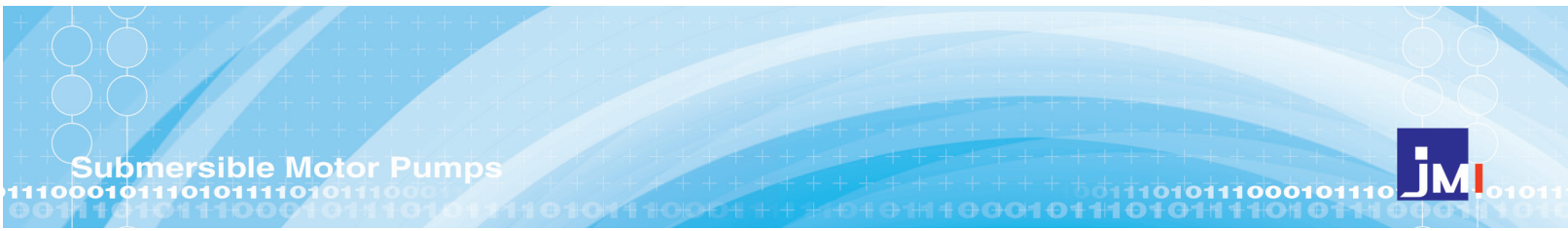
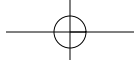

Drawing

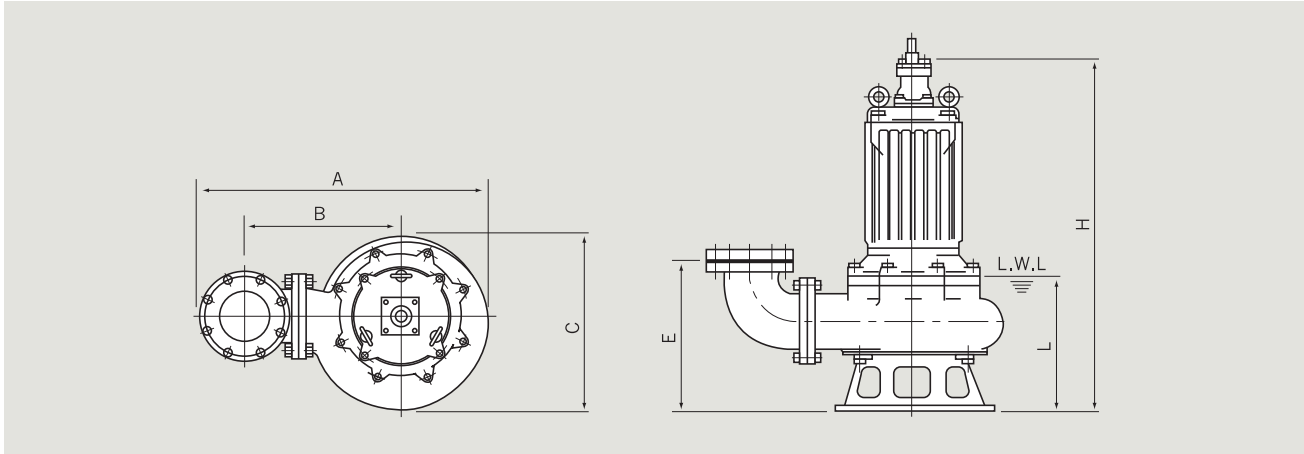

Standard model

Discharge (mm)	MODEL	Output (Kw)	Head (M)	Capacity (m ³ /min)	A (mm)	B (mm)	C (mm)	E (mm)	H (mm)	L (mm)	Weight (Kg)
50	50JPS0.75T	0.75	10	0.2	350	250	170	200	430	200	40
	50JPS1.5T	1.5	8	0.5	480	270	210	220	400	250	50
80	80JPS2.2T	2.2	10	0.6	620	330	340	310	640	350	100
	80JPS3.7T	3.7	15	0.6	700	390	400	310	650	350	120
100	100JPS5.5T	5.5	16	1.0	710	400	410	315	690	400	250
	100JPS7.5T	7.5	18	1.0	710	400	410	315	690	400	260
150	150JPS3.7T	3.7	5	2.5	780	420	410	450	750	410	270
	150JPS7.5T	7.5	9	2.5	910	540	460	420	970	450	280
	150JPS11T	11	15	2.5	910	540	460	420	970	450	330
	150JPS15T	15	20	2.5	910	540	460	420	970	450	340
	150JPS19T	19	25	2.5	1100	680	570	500	1240	490	550
200	200JPS11T	11	9	4.5	940	580	355	430	860	500	350
	200JPS15T	15	13	4.5	940	580	355	430	860	500	360
	200JPS22T	22	18	4.5	965	580	450	475	1090	550	600
	200JPS30T	30	23	4.5	965	580	450	475	1090	550	640
	200JPS37T	37	28	4.5	975	580	465	475	1145	600	670
	200JPS55T	55	40	4.5	975	580	465	475	1145	600	1280
250	250JPS11T	11	7	3	1010	690	450	570	1050	550	520
	250JPS15T	15	9	3.5	1010	690	450	570	1050	550	530
	250JPS19T	19	10	5.5	1510	690	700	660	1035	550	650
	250JPS22T	22	11.5	7	965	580	450	675	1090	550	790
	250JPS30T	30	15	6.5	965	580	450	675	1090	550	950
	250JPS37T	37	19	7	975	580	465	675	1145	600	1090
	250JPS45T	45	26	6	975	580	465	675	1145	600	1150
	250JPS55T	55	30	7	975	580	465	675	1145	600	1320

Discharge (mm)	MODEL	Output (Kw)	Head (M)	Capacity (m ³ /min)	A (mm)	B (mm)	C (mm)	E (mm)	H (mm)	L (mm)	Weight (Kg)
250	250JPS75T	75	40	7	975	580	465	675	1145	600	1400
	300JPS15T	15	6.5	9	1460	870	720	595	1090	550	690
	300JPS22T	22	9	10	1460	870	720	595	1200	700	940
300	300JPS30T	30	11.5	10	1460	870	720	595	1200	700	1030
	300JPS37T	37	15	10	1460	870	720	595	1260	750	1120
	300JPS45T	45	18	10	1460	870	720	595	1260	750	1320
	300JPS55T	55	21	10	1460	870	720	595	1260	750	1550
	300JPS75T	75	30	10	1460	870	720	595	1260	750	1840
350	350JPS90T	90	45	10	1460	870	720	595	1540	900	1950
	350JPS22T	22	5.5	15	1900	1150	940	970	1580	900	1550
	350JPS30T	30	7.5	15	1900	1150	940	970	1580	900	1610
	350JPS37T	37	9.5	15	1900	1150	940	970	1580	900	1720
	350JPS45T	45	12	15	1900	1150	940	970	1580	900	1780
400	350JPS55T	55	17	15	1460	870	720	595	1390	800	1900
	400JPS22T	22	4	20	2100	1350	1150	1270	1700	1000	1790
	400JPS37T	37	7	20	2100	1350	1150	1270	1700	1000	2070
	400JPS45T	45	9	20	2100	1350	1150	1270	1700	1000	2240
	400JPS55T	55	11	20	2100	1350	1150	1270	1700	1000	2400
500	400JPS65T	65	13	20	2060	1310	940	1000	1610	950	2470
	400JPS75T	75	15	20	2060	1310	940	1000	1610	950	2470
	400JPS110T	110	18	20	2200	1310	950	1010	2000	1250	2700
	400JPS280T	280	48	20	2500	1525	1000	1670	2300	1300	3000
	500JPS37T	37	5	30	2460	1470	1050	1000	1620	950	2070
500	500JPS55T	55	7.5	30	2460	1470	1050	1000	1620	950	2300
	500JPS75T	75	10	30	2460	1470	1050	1000	1620	950	2760



Submersible Motor Pumps



JPP

Submersible axial flow propeller pump



Motor

- 4~24 pole
- Insulation Class : F
- 3Phase/220V/380V/440V/3300V
- 1500~250rpm
- Star Delta(15KW~75KW)
Reactor(75KW~750KW)
- Standard Power : 15KW~750KW

Pump

- Impeller : Axial flow type(Propeller)
- Material
 - Propeller : Bronze/Stainless Steel
 - Casing : Cast Iron
 - Shaft : SCM440/SUS410

Drawing

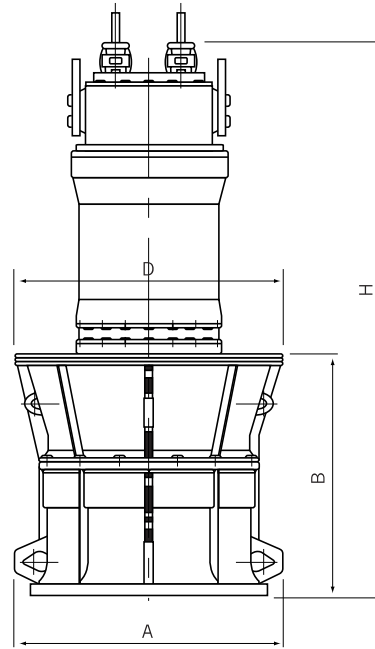

Application

- Protection from flood, heavy rain
- Drain large quantity for irrigation, agricultural water
- Reserve water for waterworks and industrial supply
- Transfer a large quantity of sewage water
- Circulate a large quantity of water a pleasure resort of park, lake



Features

- Easy to handle, install with close, compact design
- Various application to low head, large quantity
- No need of special piping or housing work
- Precisely designed impeller(propeller) by means of axial flow
- Perfect watertight with double mechanical seal
- Minimizing the cost of installation

Performance curve

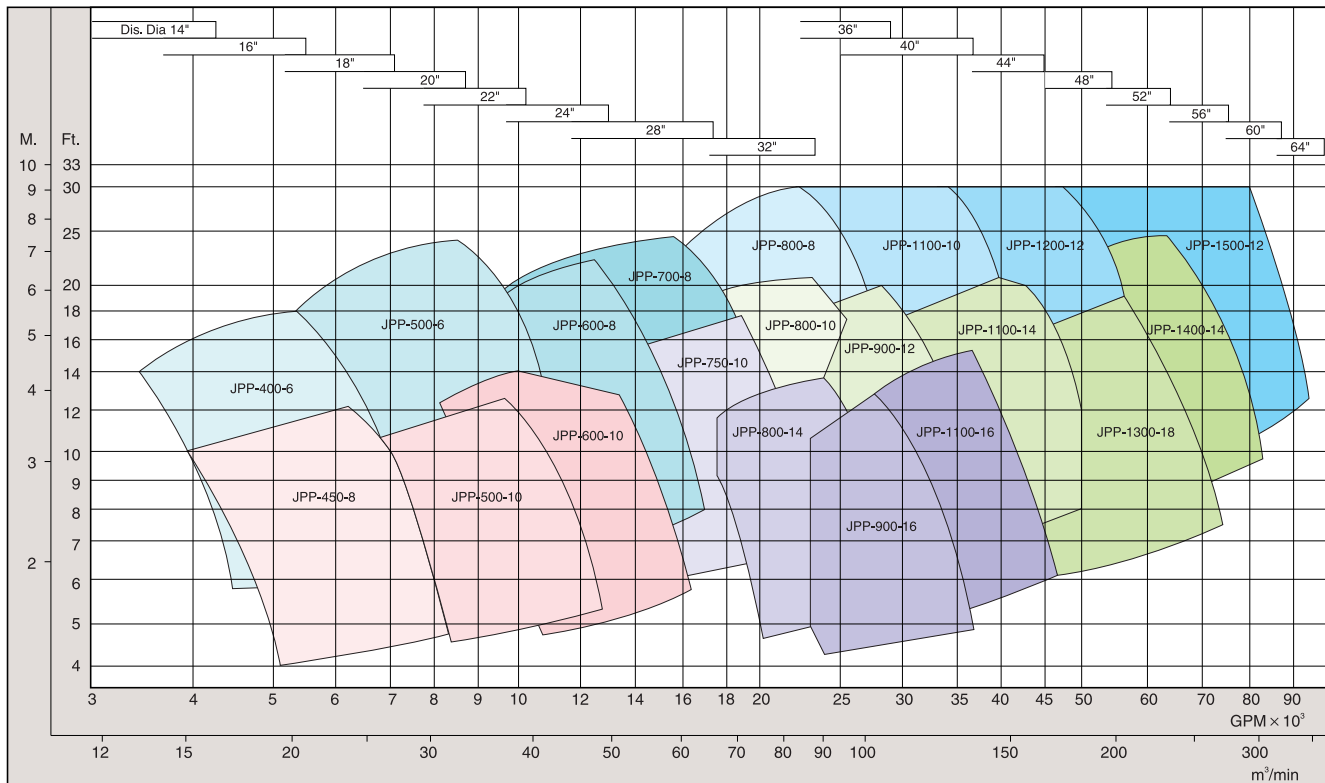

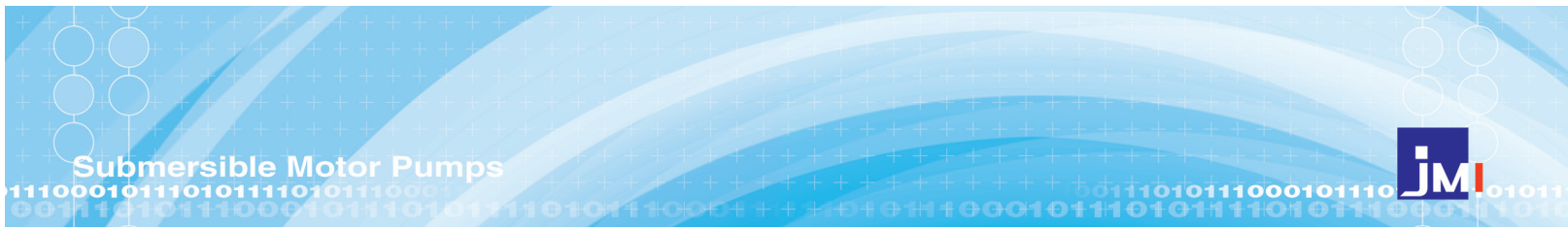
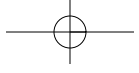

● Standard model

Discharge (mm)	MODEL	Output (Kw)	Head (M)	Capacity (m ³ /min)	A (mm)	B (mm)	D (mm)	H (mm)	Weight (Kg)
400	400JPP22 6T	22	4.5	20	560	450	570	1200	805
	400JPP30 6T	30	5.2	23	560	450	570	1200	860
500	500JPP30 6T	30	5	25	560	450	570	1300	860
	500JPP37 6T	37	5.5	28	560	450	570	1300	1090
	500JPP45 6T	45	5.6	33	560	450	570	1300	1380
	500JPP55 6T	55	6.5	35	560	450	570	1600	1720
	500JPP22 10T	22	3	30	660	600	750	1950	1035
	500JPP30 10T	30	3.5	35	660	600	750	1950	1150
	500JPP37 10T	37	3.6	43	660	600	750	1950	1260
	600JPP37 8T	37	4.3	35	760	710	750	1700	1090
600	600JPP45 8T	45	4.7	40	760	710	750	1700	1610
	600JPP55 8T	55	5.5	42	760	710	750	1950	1840
	600JPP65 8T	65	5.7	50	760	710	750	1950	2070
	600JPP75 8T	75	5.8	55	760	710	750	1950	2300
	600JPP30 10T	30	3.5	35	870	800	860	1900	1150
	600JPP37 10T	37	3.6	43	870	800	860	2150	1260
	600JPP45 10T	45	4	47	870	800	860	2150	2300
	600JPP55 10T	55	4.6	50	980	940	930	2400	2750
700	700JPP55 12T	55	5	45	970	830	950	2160	2185
	700JPP75 10T	75	5.6	55	970	830	950	2200	2300
	700JPP90 10T	90	6	63	970	830	950	2200	2470
	700JPP110 10T	110	6.5	71	970	830	950	2200	2990
800	800JPP90 8T	90	6.2	62	950	850	930	2150	2470
	800JPP110 8T	110	6.7	70	950	850	930	2300	2990
	800JPP130 8T	130	7.2	77	1050	900	1050	2300	3680
	800JPP150 8T	150	7.5	88	1050	900	1050	2450	4370
	800JPP190 8T	190	8.2	100	1050	900	1050	2450	5520
	800JPP75 10T	75	4.7	68	1160	1100	1150	2600	2870
	800JPP90 10T	90	5.2	74	1160	1100	1150	2600	3560
	800JPP110 10T	110	5.7	82	1160	1100	1150	2850	4020
900	800JPP130 10T	130	6	92	1160	1100	1150	2850	4370
	800JPP110 12T	110	3.7	79.8	1065	880	1050	2460	4140
	900JPP75 12T	75	4	80	1065	920	1050	2300	3565
	900JPP90 12T	90	4.5	87	1065	920	1050	2300	3680
	900JPP110 12T	110	5	96	1065	920	1050	2450	4370
	900JPP130 12T	130	5.5	103	1065	920	1050	2450	5170
	900JPP150 12T	150	3.7	110	1165	1085	1150	2700	5400
	900JPP110 14T	110	4.3	105	1165	1085	1150	2650	5060
900	900JPP55 16T	55	3	78	1200	980	1150	2350	4250
	900JPP75 16T	75	3.5	93	1200	980	1150	2350	4710

Discharge (mm)	MODEL	Output (Kw)	Head (M)	Capacity (m ³ /min)	A (mm)	B (mm)	D (mm)	H (mm)	Weight (Kg)
900	900JPP90 16T	90	4	98	1200	980	1150	2350	5170
	900JPP110 16T	110	4	120	1400	1080	1400	2400	5750
1000	1000JPP150 14T	150	4.5	129	1165	1085	1150	2700	4940
	1000JPP150 16T	150	4.5	135	1265	1110	1250	2750	5520
1100	1100JPP130 10T	130	5.9	95	1065	920	1050	2300	4370
	1100JPP150 10T	150	6.2	105	1065	920	1050	2300	5170
	1100JPP190 10T	190	7	118	1065	920	1050	2400	6670
	1100JPP220 10T	220	7.5	128	1065	920	1050	2400	7240
	1100JPP110 14T	110	4.2	115	1265	1100	1250	2500	5170
	1100JPP130 14T	130	4.4	130	1265	1100	1250	2700	5750
	1100JPP150 14T	150	4.9	135	1265	1100	1250	2700	7240
	1100JPP190 14T	190	5.5	152	1265	1100	1250	2700	7590
	1100JPP220 14T	220	6	162	1265	1100	1250	2850	7820
	1100JPP75 16T	75	3.5	94	1265	1100	1250	2500	4710
	1100JPP110 16T	110	4	120	1265	1100	1250	2700	5750
	1100JPP130 16T	130	4.5	125	1265	1100	1250	2700	6320
1200	1100JPP150 16T	150	4.9	135	1265	1100	1250	2700	7470
	1200JPP190 12T	190	6	139	1165	1085	1170	3000	7240
	1200JPP220 12T	220	6.5	149	1165	1085	1170	3000	7470
	1200JPP250 12T	250	6.9	160	1165	1085	1170	3000	8160
1300	1200JPP270 12T	270	7	170	1165	1085	1170	3000	8390
	1200JPP300 12T	300	7.4	180	1165	1085	1170	3300	8740
	1200JPP350 12T	350	7.8	200	1465	1325	1450	3400	9430
	1200JPP260 16T	260	7	180	1465	1325	1450	3200	8970
1400	1300JPP150 18T	150	4	165	1560	1420	1550	3200	9100
	1300JPP190 18T	190	4.4	190	1560	1420	1550	3200	9360
	1300JPP220 16T	220	5	195	1560	1420	1550	3450	10070
	1300JPP250 14T	250	5.5	202	1560	1420	1550	3450	10240
1500	1300JPP300 14T	300	5.8	225	1560	1420	1550	3870	10580
	1400JPP190 14T	190	5	162	1560	1420	1550	3450	9660
	1400JPP220 14T	220	5.5	175	1560	1420	1550	3450	9890
	1400JPP250 14T	250	6	185	1560	1420	1550	3450	11270
	1400JPP300 12T	300	6.5	206	1560	1420	1550	3870	9660
	1400JPP350 12T	350	7	220	1560	1420	1550	3870	11500
	1400JPP400 12T	400	7.4	240	1560	1420	1550	3870	11700
	1500JPP300 14T	300	6.2	215	1560	1420	1550	3900	10810
1500	1500JPP350 14T	350	6.5	240	1560	1420	1550	3900	11500
	1500JPP400 12T	400	7.1	250	1560	1420	1550	3900	11700
	1500JPP450 12T	450	7.5	265	1560	1420	1550	3900	12000
1500JPP500 12T	500	8	275	1560	1420	1550	3900	12300	

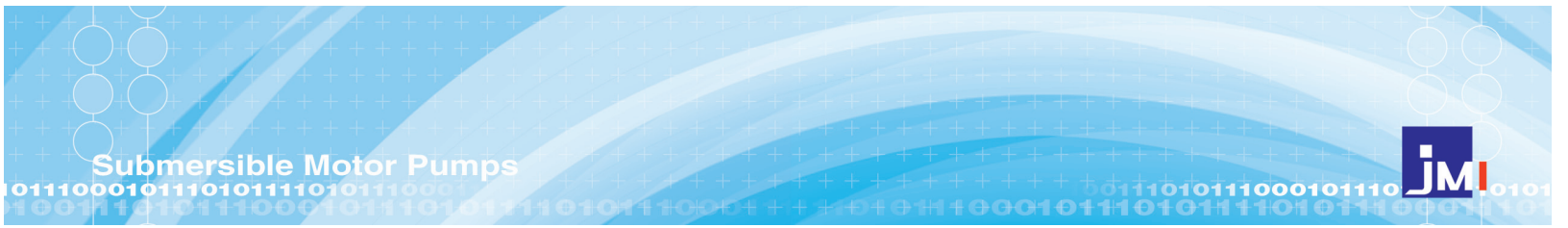

JPM

Submersible mixed flow pump



- **Motor**
 - 4~24 pole
 - Insulation Class : F
 - 3Phase/220V/380V/440V/3300V
 - 1500~250rpm
 - Star Delta(22KW~75KW)
 - Reactor(75KW~750KW)
 - Standard Power : 22KW~750KW
- **Pump**
 - Impeller : Mixed Flow Type
 - Material
 - Propeller : Bronze/Stainless Steel
 - Casing : Cast Iron/SCS13
 - Shaft : SCM440/SUS410

● **Drawing**

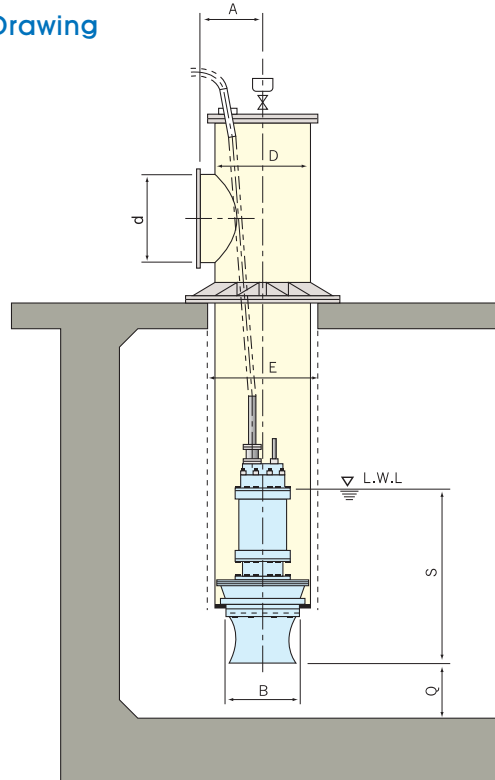

● **Application**

- Protection from flood, heavy rain
- Drain large quantity for irrigation, agricultural water
- Reserve water for waterworks and industrial supply
- Transfer a large quantity of sewage water
- Circulate a large quantity of water a pleasure resort of park, lake



● **Features**

- Easy to handle, install with close, compact design
- Various application to middle head, large quantity
- No need of special piping or housing work
- Perfect watertight with double mechanical seal
- Minimizing the cost of installation

● **Performance curve**

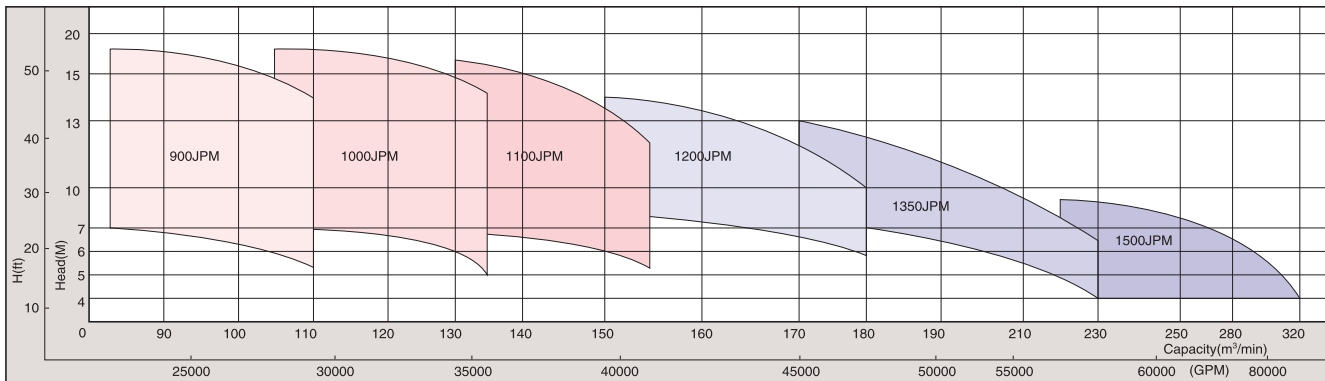
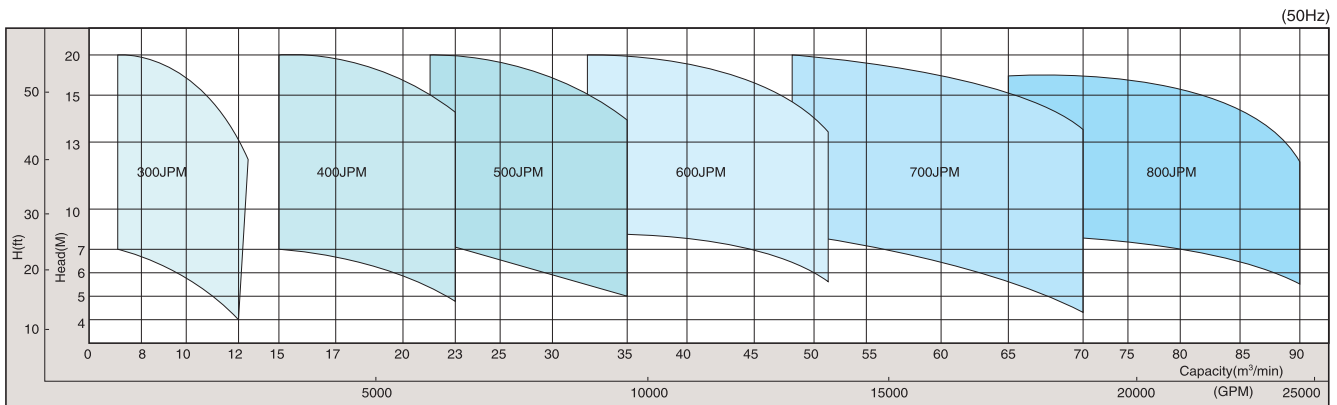

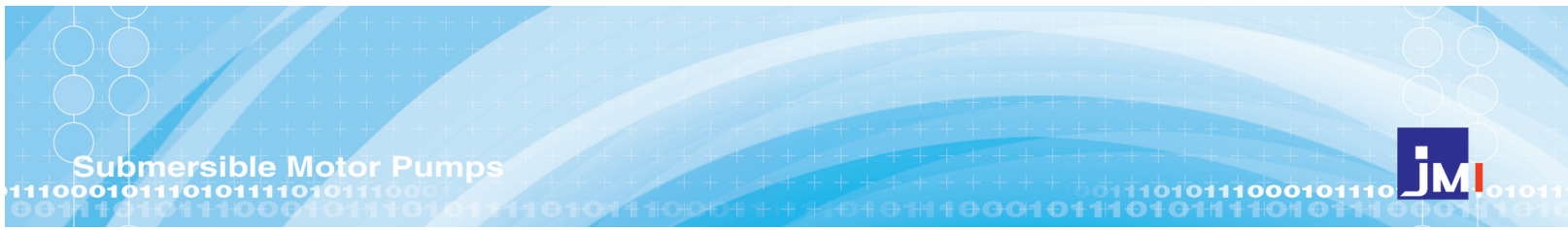
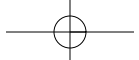

● Standard model

Discharged (mm)	MODEL	Output (Kw)	Head (M)	Capacity (m ³ /min)	A (mm)	B (mm)	E (mm)	Q (mm)	S (mm)	D (mm)
250	250JPM15 6T	15	8	6	450	370	600	250	710	500
	300JPM22 6T	22	9	10	500	510	700	300	750	600
300	300JPM37 4T	37	15	10	500	510	700	300	750	600
	400JPM30 10T	30	5	20	532	630	900	400	950	800
400	400JPM37 8T	37	7.5	20	532	630	900	400	950	800
	400JPM45 8T	45	9.5	20	470	530	800	300	1000	700
	400JPM55 6T	55	11.5	20	470	530	800	300	1000	700
	400JPM75 6T	75	15.5	20	470	530	800	300	1000	700
	400JPM90 6T	90	18.5	20	470	530	800	300	1000	700
	500JPM37 10T	37	5	30	550	630	900	350	950	800
500	500JPM55 12T	55	7.5	30	550	680	900	400	1000	800
	500JPM75 8T	75	10.5	30	550	680	900	400	1000	800
	500JPM110 8T	110	15	30	550	680	900	400	1000	800
	500JPM150 8T	150	18	30	550	680	900	400	1000	800
600	600JPM75 14T	75	7	45	600	780	1000	450	1100	900
	600JPM90 12T	90	8.5	45	600	780	1000	450	1100	900
	600JPM130 10T	130	12.5	45	600	780	1000	450	1100	900
	600JPM150 8T	150	14.6	45	600	780	1000	450	1100	900
	600JPM190 8T	190	17.5	45	600	780	1000	450	1100	900
	700JPM90 16T	90	6.5	60	630	800	1100	450	1400	1000
700	700JPM110 14T	110	8	60	630	800	1100	450	1400	1000
	700JPM150 12T	150	10.8	60	630	800	1100	450	1400	1000
	700JPM220 10T	220	16	60	630	800	1100	450	1400	1000
	700JPM260 8T	260	18.5	60	630	800	1100	450	1400	1000
800	800JPM130 16T	130	7	80	710	900	1200	500	1600	1100
	800JPM150 12T	150	8	80	710	900	1200	500	1600	1100
	800JPM190 14T	190	10	80	710	900	1200	500	1600	1100
	800JPM220 12T	220	12	80	710	900	1200	500	1600	1100

Discharged (mm)	MODEL	Output (Kw)	Head (M)	Capacity (m ³ /min)	A (mm)	B (mm)	E (mm)	Q (mm)	S (mm)	D (mm)
800	800JPM300 10T	300	16.3	80	710	900	1200	500	1600	1100
900	900JPM150 8T	150	6.3	100	770	1000	1300	700	2200	1200
	900JPM185 12T	185	7.3	100	770	1000	1300	700	2200	1200
900	900JPM220 6T	220	9.3	100	770	1000	1300	700	2200	1200
	900JPM300 6T	300	12.5	100	770	1000	1300	700	2200	1200
	900JPM350 6T	350	14.7	100	770	1000	1300	700	2200	1200
	900JPM400 6T	400	16.9	100	770	1000	1300	700	2200	1200
1000	1000JPM190 8T	190	6.7	120	890	1200	1500	700	2000	1400
	1000JPM220 8T	220	7.8	120	890	1200	1500	700	2000	1400
	1000JPM275 16T	275	9.7	120	890	1200	1500	700	2000	1400
	1000JPM300 6T	300	10.7	120	890	1200	1500	700	2000	1400
	1000JPM400 6T	400	14.2	120	890	1200	1500	700	2000	1400
	1000JPM500 6T	500	17.7	120	890	1200	1500	700	2000	1400
1100	1100JPM220 8T	220	6.7	140	1000	1300	1500	600	1650	1400
	1100JPM300 8T	300	9	140	1000	1300	1500	600	1650	1400
	1100JPM400 6T	400	12.2	140	1000	1300	1500	600	1650	1400
	1100JPM450 6T	450	13.7	140	1000	1300	1500	600	1650	1400
	1100JPM500 6T	500	15.2	140	1000	1300	1500	600	1650	1400
	1200JPM300 8T	300	8.1	160	1000	1400	1600	600	1800	1500
1200	1200JPM355 8T	355	9.4	160	1000	1400	1600	600	1800	1500
	1200JPM400 8T	400	10.8	160	1000	1400	1600	600	1800	1500
	1200JPM450 6T	450	12.1	160	1000	1400	1600	600	1800	1500
	1200JPM500 6T	500	13.5	160	1000	1400	1600	600	1800	1500
1350	1350JPM300 8T	300	6.9	190	1150	1500	1750	700	2000	1600
	1350JPM400 8T	400	9.1	190	1150	1500	1750	700	2000	1600
1500	1350JPM500 8T	500	11.4	190	1150	1500	1750	700	2000	1600
	1500JPM400 10T	400	7	250	1250	1600	1950	750	2200	1700
1500	1500JPM500 8T	500	8.7	250	1250	1600	1950	750	2200	1700



Submersible Motor Pumps

JPW Waste water and effluent pump



- Motor**
 - 2 pole
 - Insulation Class : F
 - 3Phase/220V/380V/440V
 - 3000rpm
 - Line Start/Star Delta
 - Standard Power : 0.75KW-30KW

- Pump**
 - Impeller : Semi open type
 - Material
 - Impeller : FC200/SCS13
 - Casing : FC200/SCS13
 - Suction cover : FC200/SCS13
 - Shaft : SCM440/SUS410
 - Connecting method
 - Flange Coupling/Hose Coupling/ Automatic Discharge connector

Application

- Transport from waste & sewage water treatment plant
- Subway station, underground, industrial site
- Fountain, decorative waterfall
- High head



Features

- High head
- Easy to maintain with Automatic Discharge Connector
- Equipped with semi-open impeller
- More than 19KW has non-pressuring structure
- Equipped with the electric motor protector
- Perfect watertight with double mechanical seal

Drawing

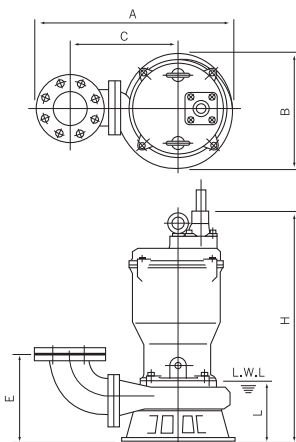

Performance curve (50Hz)

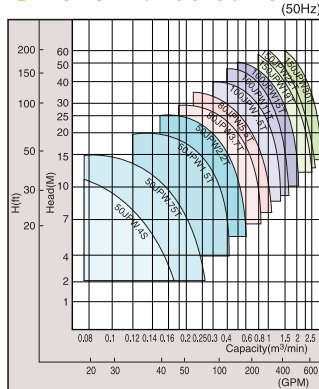

Standard model

Discharge (mm)	MODEL	Output (Kw)	Head (M)	Capacity (m³/min)	A (mm)	B (mm)	C (mm)	E (mm)	H (mm)	L (mm)	Weight (Kg)
50	50JPW0.4S	0.4	8	0.12	250	127	173	99	450	80	20
	50JPW0.75S	0.75	10	0.16	250	127	173	99	470	80	25
	50JPW0.75T	0.75	10	0.16	350	170	200	210	465	330	40
	50JPW1.5T	1.5	15	0.25	395	215	220	215	505	330	65
	50JPW2.2T	2.2	20	0.30	395	215	220	215	530	330	70
80	80JPW3.7T	3.7	20	0.50	535	256	310	240	590	400	75
	80JPW5.5T	5.5	25	0.60	535	256	310	240	640	450	97
	100JPW7.5T	7.5	30	0.80	710	410	400	315	820	600	185
100	100JPW11T	11	35	1.0	710	410	400	315	885	600	210
	100JPW15T	15	40	1.20	710	410	400	315	885	600	230
	150JPW19T	19	30	2.0	940	460	570	420	969	650	360
150	150JPW22T	22	35	2.0	940	460	570	420	969	650	370
	150JPW30T	30	45	2.50	940	460	570	420	969	650	390
	150JPW37T	37	50	2.0	940	475	570	450	1020	700	420

JPG Sand and Gravel effluent pump

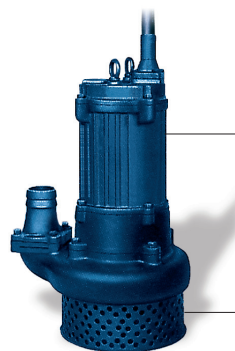

- Motor**
 - 4-6 pole
 - Insulation Class : F
 - 3Phase/220V/380V/440V
 - 1500-1000rpm
 - Line Start(2.2KW~15KW) Star Delta(15KW~110KW)
 - Standard Power : 2.2KW~110KW

- Pump**
 - Impeller : semi open type
 - Material
 - Impeller : Hi-Cr/SCS13
 - Agitator : Hi-Cr
 - Casing : FC200/SCS13
 - Shaft : SCM440/SUS410
 - Suction cover : Hi-Cr/SCS13
 - Connecting method
 - Flange Coupling/Hose Coupling

Application

- Transport of sand, gravel and sediment at a bottom
- Dredging operation in harbor
- Moving gravel and sand
- Drainage from construction site
- Drainage of underground construction
- Drainage and supplying of tunnel construction



Features

- Increase of the abrasive resistance by using Hr-Cr of impeller and Agitator
- Smoothed drainage of sediment and sand by agitator
- Easy to carry with light weight
- Including the electric motor protector

Drawing

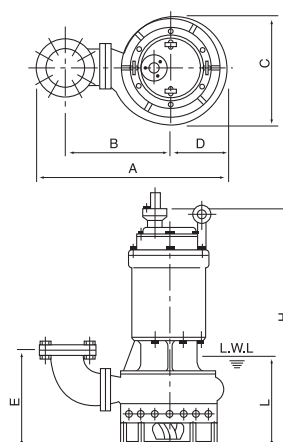

Performance curve (50Hz)

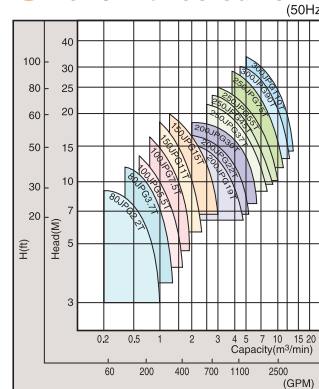

Standard model

Discharge (mm)	MODEL	Output (Kw)	Head (M)	Capacity (m³/min)	A (mm)	B (mm)	C (mm)	D (mm)	E (mm)	H (mm)	L (mm)	Weight (Kg)
80	80JPG2.2T	2.2	6	0.70	470	230	345	180	205	650	210	110
	80JPG3.7T	3.7	8	0.90	470	230	345	180	205	690	210	120
100	100JPG5.5T	5.5	10	1.00	525	250	370	210	245	840	255	150
	100JPG7.5T	7.5	12	1.25	525	250	370	210	245	840	255	175
	150JPG11T	11	14	1.65	570	275	450	225	280	940	290	200
150	150JPG15T	15	14	2.30	570	275	450	225	280	940	290	230
	200JPG19T	19	13	3.05	880	420	580	320	590	1310	550	580
	200JPG22T	22	13	3.60	880	420	580	320	590	1310	550	610
200	200JPG30T	30	13	5.00	990	480	700	340	680	1600	570	650
	250JPG37T	37	16	5.00	990	480	700	340	680	1600	570	890
	250JPG45T	45	18	5.40	990	480	700	340	680	1600	570	930
250	250JPG55T	55	18	6.50	990	480	640	340	680	1600	570	1050
	250JPG75T	75	22	7.50	1170	635	680	340	780	1685	750	1150
300	300JPG90T	90	24	8.20	1170	635	680	340	780	1685	750	1350
	300JPG110T	110	24	10.00	1200	635	680	340	780	1685	750	1500



Submersible Motor Pumps



JPD

Drainage pump for civil engineering site



- Motor**
 - 2 Pole
 - Insulation Class : F
 - 3Phase/220V/380V/440V
 - 3000rpm
 - Line Start
 - Standard Power : 0.75KW~15KW
- Pump**
 - Impeller : Semi-open type
 - Material
 - Impeller : FC200/SCS13
 - Casing : FC200
 - Suction cover : FC200/SCS13
 - Shaft : SCM440/SUS410
 - Connecting method
 - Flange coupling/Hose coupling

- Application**
 - Pumping/drainage at a industrial site, engineering
 - Pumping/drainage at underground, subway station
 - Fountain, tunnel construction site



- Features**
 - Easy to move due to light weight, compact structure
 - Applicable to high or low head according to its purpose by means of changing impeller
 - Maximize cooling effect of motor with waterway structure beside motor
 - Motor protector built in.
 - Perfect watertight with double mechanical seal

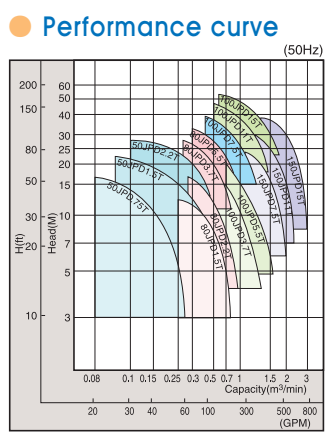
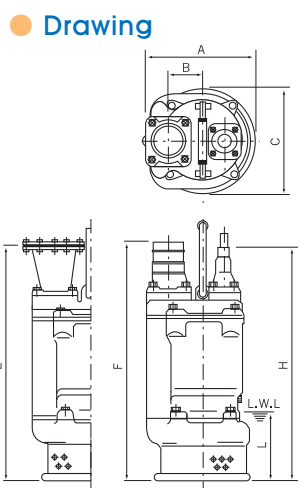

Standard model

Discharge (mm)	MODEL	Output (Kw)	Head (M)	Capacity (m³/min)	A (mm)	B (mm)	C (mm)	E (mm)	F (mm)	H (mm)	L (mm)	Weight (Kg)
50	50JPD1.5T	1.5	15	0.25	235	80	215	520	535	490	150	45
	50JPD2.2T	2.2	20	0.30	235	80	215	545	535	515	150	50
80	80JPD1.5T	1.5	8	0.50	235	80	215	535	535	490	150	45
	80JPD2.2T	2.2	10	0.60	235	80	215	535	535	515	150	50
	80JPD3.7T	3.7	20	0.50	285	105	250	670	630	580	180	70
	80JPD5.5T	5.5	25	0.60	285	105	250	670	630	630	180	83
	100JPD3.7T	3.7	10	1.0	285	105	250	670	645	580	180	70
	100JPD5.5T	5.5	15	1.0	285	105	250	670	695	630	180	83
100	100JPD7.5T	7.5	30	0.80	360	130	325	855	830	815	250	150
	100JPD11T	11	35	1.00	360	130	325	855	870	855	250	177
	100JPD15T	15	40	1.20	360	130	325	895	870	855	250	180
150	150JPD7.5T	7.5	15	1.60	360	130	325	945	890	815	250	150
	150JPD11T	11	20	1.70	360	130	325	985	930	855	250	177
	150JPD15T	15	20	2.50	360	130	325	985	930	855	250	180

JPDL

Drainage pump for civil engineering site



- Motor**
 - 4 Pole
 - Insulation Class : F
 - 3Phase/220V/380V/440
 - 1500rpm
 - Line Start(2.2KW~15KW) / Star Delta(15KW~37KW)
 - Standard Power : 2.2~37KW
- Pump**
 - Impeller : Semi-open type
 - Material
 - Impeller : FC200/SCS13
 - Casing : FC200
 - Suction cover : FC200/SCS13
 - Shaft : SCM440/SUS410
 - Connecting method
 - Flange coupling/Hose coupling

- Application**
 - Pumping/drainage at engineering, construction site
 - Dewatering/drainage at waterworks/sewage construction site
 - Fountain application



- Features**
 - Light weight
 - Supply, drain water with low horsepower
 - Increase durability with 4 pole
 - Cooling effect of motor

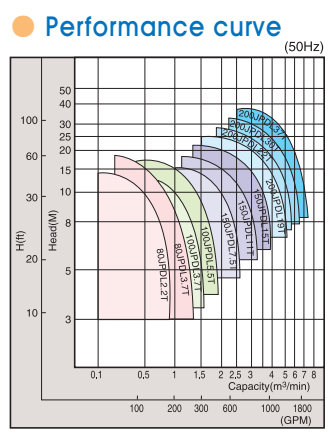
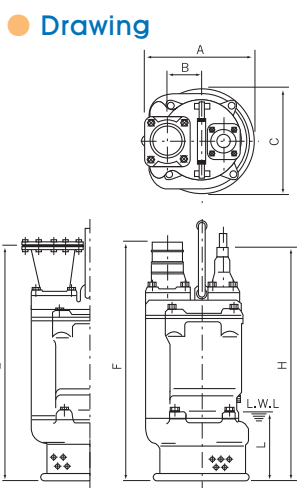

Standard model

Discharge (mm)	MODEL	Output (Kw)	Head (M)	Capacity (m³/min)	A (mm)	B (mm)	C (mm)	E (mm)	F (mm)	H (mm)	L (mm)	Weight (Kg)
80	80JPDL2.2T	2.2	10	0.5	295	122	222	745	725	660	210	110
	80JPDL3.7T	3.7	15	0.5	295	122	222	745	725	660	210	120
100	100JPDL3.7T	3.7	10	1.0	295	122	222	745	725	660	210	121
	100JPDL5.5T	5.5	15	1.0	360	140	322	795	770	705	230	135
	150JPDL7.5T	7.5	10	2.0	430	145	395	920	920	870	250	210
150	150JPDL11T	11	15	2.0	430	145	395	920	920	870	250	220
	150JPDL15T	15	15	3.0	430	145	395	955	955	905	250	245
200	200JPDL19T	19	15	4.0	620	154	565	1230	1320	1180	330	420
	200JPDL22T	22	18	4.0	620	154	565	1320	1320	1180	330	450
	200JPDL30T	30	25	4.0	620	154	565	1320	1320	1180	330	480
	200JPDL37T	37	30	4.5	680	200	600	1420	1470	1330	400	600



Submersible Motor Pumps

JPH High head dewatering pump for civil engineering site



- Motor**
 - 2 pole
 - Insulation Class : F
 - 3Phase/220V/380V/440V
 - 3000rpm
 - Star-Delta
 - Standard Power : 22KW~110KW
- Pump**
 - Impeller : Enclosed type
 - Material
 - Impeller : BC 6
 - Casing : FC200/SCS13
 - Suction cover : FC200/SCS13
 - Shaft : SCM440/SUS410
 - Connecting Method
 - Flange Coupling/Hose Coupling

- Application**
 - High head
 - Drainage at mine
 - Long-distance pressuring dewatering/drainage at golf link & reservoir
 - Dewatering/drainage at road, harbor, dam construction site



- Features**
 - Applicable to higher head than other dewatering pumps with 2 poles and enclosed impeller
 - Maximize cooling effect of motor with water jacket around motor
 - Including motor protector
 - Perfect watertight with double mechanical seal

Drawing

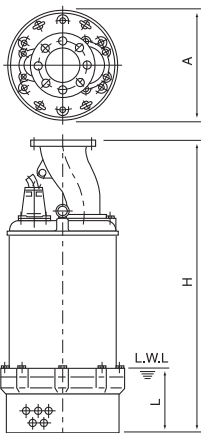

Performance curve

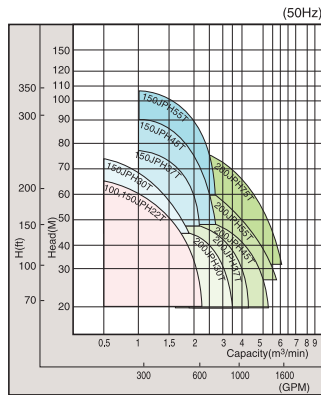

Standard model

Discharge (mm)	MODEL	Output (Kw)	Head (M)	Capacity (m³/min)	A (mm)	H (mm)	L (mm)	Weight (Kg)
100	100JPH22T	22	60	1.0	470	1350	300	500
	150JPH22T	22	35	2.0	470	1350	300	500
150	150JPH30T	30	60	1.4	470	1350	300	530
	150JPH37T	37	60	2.0	620	1545	350	770
	150JPH45T	45	60	2.5	620	1545	350	800
	150JPH55T	55	90	2.0	620	1545	350	820
200	200JPH30T	30	35	2.7	470	1350	300	530
	200JPH37T	37	35	3.6	620	1545	350	770
	200JPH45T	45	35	4.5	620	1545	350	800
	200JPH55T	55	50	4.0	620	1545	350	820
	200JPH75T	75	60	4.5	620	1545	350	820

JPHH High head dewatering pump for civil engineering site



- Motor**
 - 2 pole
 - Insulation Class : F
 - 3Phase/220V/380V/440V
 - 3000rpm
 - Line Start(5.5KW~15KW)
 - Star-Delta(15KW~110KW)
 - Standard Power : 5.5KW~110KW
- Pump**
 - Impeller : Enclosed type
 - Material
 - Impeller : Bc 6
 - Casing : FC200/SCS13
 - Suction cover : FC200/SCS13
 - Shaft : SCM440/SUS410
 - Connecting Method
 - Flange coupling/Hose coupling

- Application**
 - High head
 - Drainage at mine
 - Long-distance pressuring dewatering/drainage at golf link & reservoir
 - Dewatering/drainage at road, harbor, dam construction site



- Features**
 - High head by using 2 stage impeller
 - Applicable to higher head with 2Poles and enclosed impeller
 - Maximize cooling effect of motor with water jacket around motor
 - Including motor protector
 - Perfect watertight with double mechanical seal

Drawing

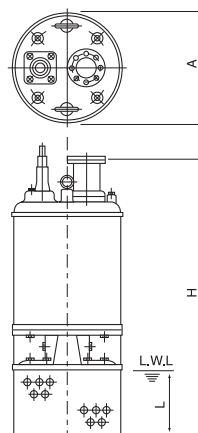

Performance curve

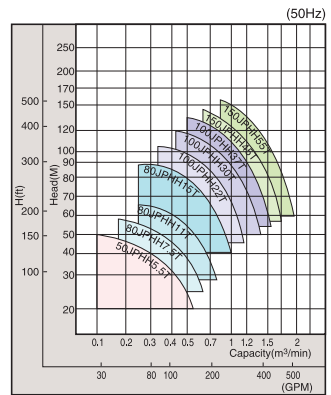

Standard model

Discharge (mm)	MODEL	Output (Kw)	Head (M)	Capacity (m³/min)	A (mm)	H (mm)	L (mm)	Weight (Kg)
50	50JPHH5.5T	5.5	40	0.30	290	670	180	150
	80JPHH7.5T	7.5	50	0.35	335	970	250	210
80	80JPHH11T	11	60	0.40	335	970	250	235
	80JPHH15T	15	80	0.50	335	970	250	250
100	100JPHH22T	22	80	0.80	470	1215	330	530
	100JPHH30T	30	100	0.80	470	1415	330	560
	100JPHH37T	37	100	1.10	520	1600	400	800
150	150JPHH45T	45	100	1.30	520	1600	400	830
	150JPHH55T	55	100	1.55	520	1600	400	850



Submersible Motor Pumps



JPR Submersible aerator

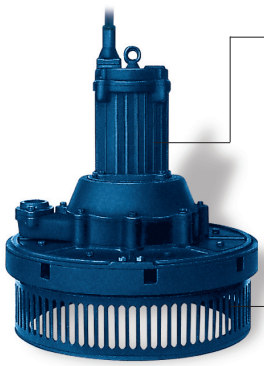

- Motor**
 - 4 pole
 - Insulation Class : F
 - 3Phase/220V/380V/440V
 - 1500rpm
 - Line Start(2.2KW~15KW)
 - Star Delta(15KW~22KW)
 - Standard Power : 2.2KW~22KW
- Aerator**
 - Impeller : Semi open type
 - Material
 - Impeller : SCS13
 - Air Suction Casing : FC200/SCS13
 - Shaft : SCM440/SUS410
 - Air Suction Cover : SCS13
 - Connecting method
 - Flange Coupling/Hose Coupling/
 - Automatic Discharge connector

- Application**
 - Aeration for industrial wastewater, excreta, sewage
 - Aeration in lake, reservoir, fish farm
 - Aeration in septic tank of A.P.T, building, industrial factory



- Features**
 - Effective air solution by means of self-air suction
 - Powerful agitator to mix, compact construction to maximize effect of minute air-bubble occurrence
 - Increase durability with 4 Pole motor, directly connected to shaft
 - Motor protector built in
 - Perfect watertight with double mechanical seal

Drawing

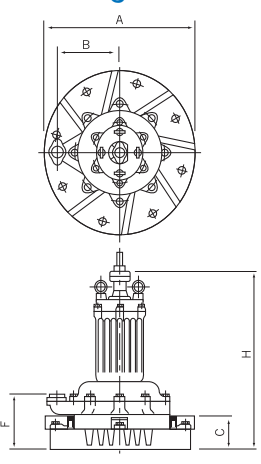

Performance curve

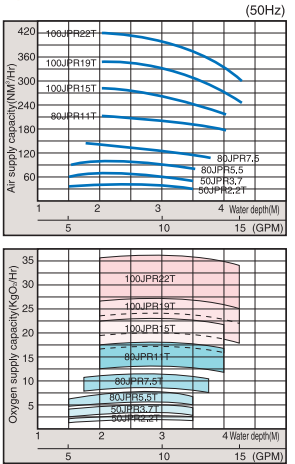

Standard model

Discharge (mm)	MODEL	Output (Kw)	Water depth (M)	Air supply capacity (Nm³/Hr)	Oxygen supply capacity (KgO₂/Hr)	Main conversion (M)	Sub conversion (M)	A (mm)	B (mm)	C (mm)	F (mm)	H (mm)	Weight (Kg)
32	32JPR0.75T	0.75	3	11	0.35~0.6	1.2	2.0	480	210	145	222	517	75
	32JPR1.5T	1.5	3	25	1.0~1.4	1.5	2.5	480	210	145	222	517	85
50	50JPR2.2T	2.2	3	36	1.8~2.8	2.5	5.0	705	270	161	265	643	190
	50JPR3.7T	3.7	3	60	3.5~5.0	3.0	6.0	705	270	161	265	643	210
80	80JPR5.5T	5.5	3	90	5.5~7.7	3.5	7.0	705	270	179	289	723	245
	80JPR7.5T	7.5	3	125	8.2~11.3	4.5	9.0	705	270	179	289	723	260
	80JPR11T	11	3	200	13~18	5.0	10.0	705	270	179	289	953	311
100	100JPR15T	15	3	260	17~23	5.5	11.0	705	270	179	289	953	325
	100JPR19T	19	3	330	20~27	6.0	12.0	1000	385	256	370	1158	600
	100JPR22T	22	3	400	24~36	6.0	12.0	1000	385	256	370	1158	650

JPX Submersible mixer

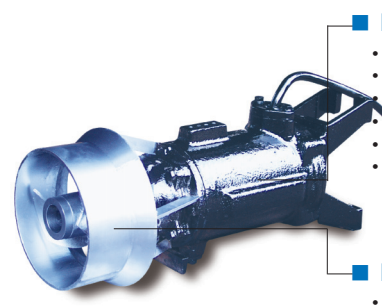

- Motor**
 - 4~8 pole
 - Insulation Class : F
 - 3Phase/220V/380V/440V
 - 500~750rpm
 - Line Start
 - Standard Power : 2.2KW~15KW
- Mixer**
 - Impeller : Propeller
 - Material
 - Impeller : SCS13
 - Shaft : SUS410

- Application**
 - Agitating at wastewater treatment plant, sediment etc.
 - Effective oxygen supply, circulation of water, prevention of freezing and temperature control at a breeding ground
 - Protection of sediment such as sand and slime at industrial plant



- Features**
 - Installed to any direction(upper, low, right or left side)
 - Prominent effect in homogenizing a various liquid and protection of sediment
 - The use of air diffuser and surface turbine to maximize aeration time
 - Simple structure

Drawing

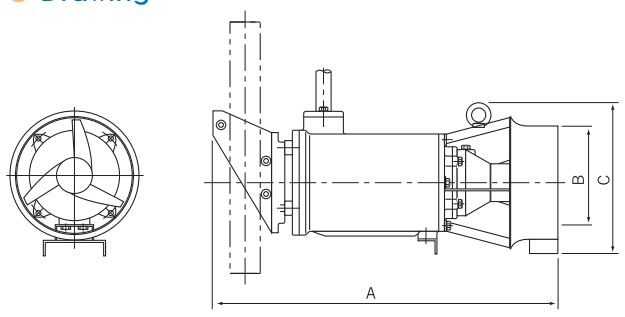

Standard model

MODEL	Output (Kw)	Revolution (R.P.M)	Maximum current speed (M/S)	Maximum tank volume (M³)	Maximum mixed range (M)	A (mm)	B (mm)	C (mm)	Weight (Kg)
JPX2.2T	2.2	1750	0.5	150	15	800	250	350	100
JPX3.7T	3.7	1750	0.5	200	20	860	250	350	110
JPX5.5T	5.5	1750	0.5	300	30	1034	280	480	155
JPX7.5T	7.5	1750	0.5	500	35	1034	280	480	165
JPX11T	11	1165	0.5	600	40	1240	420	570	280
JPX15T	15	875	0.5	800	45	1400	560	670	300

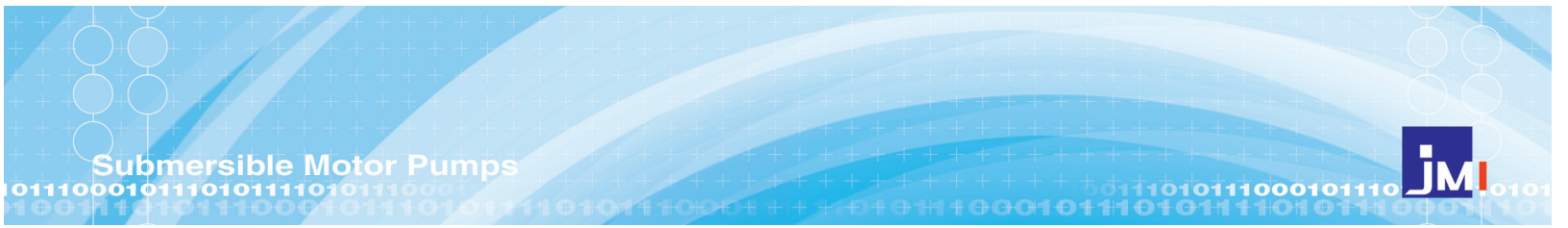

Submersible Motor Pumps



JPA

Submersible aquarator

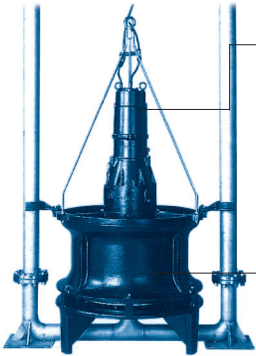

Motor

- 4-6 Pole
- Insulation Class : F
- 3Phase/220V/380V/440V
- 1500~1000rpm
- Line Start(5.5KW~15KW)
Star Delta(15KW~30KW)
- Standard Power : 5.5KW~30KW

Aquarator

- Impeller : Propeller type
- Material
-Impeller : Stainless Steel
-Casing : Cast Iron
-Shaft : Stainless Steel(SUS410)

Application

- Consist of aerating and agitating function
- For sewage water treatment plant
- For wastewater treatment plant



Features

- High Oxygenating efficiency with the structure of downward discharge system
- Prevention of sediment with Large agitating capacity and high speed Current at the bottom of aeration tank
- Agitating operation can be continued even though air supply from blower is suspended
- Minimizing the cost of installation

Drawing

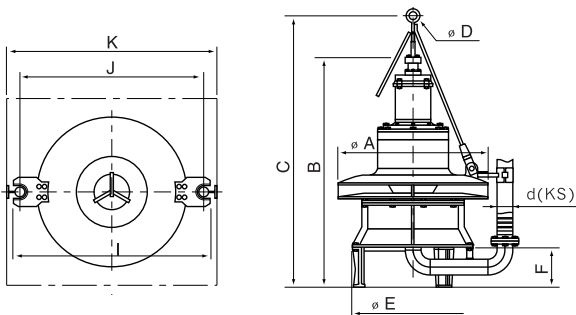

Performance curve

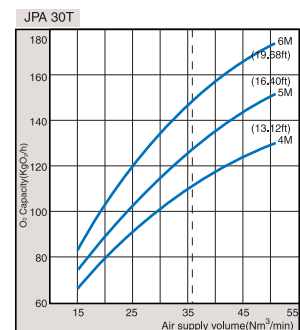
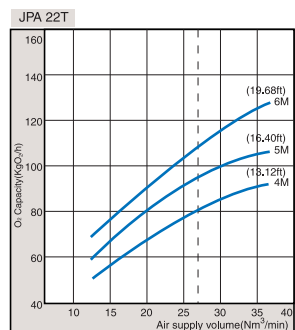
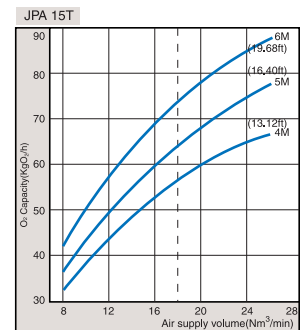
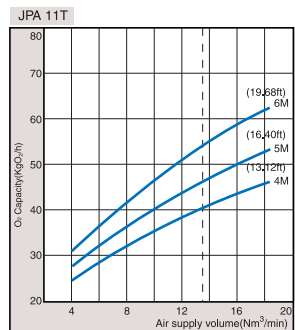
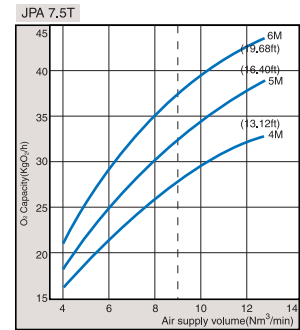
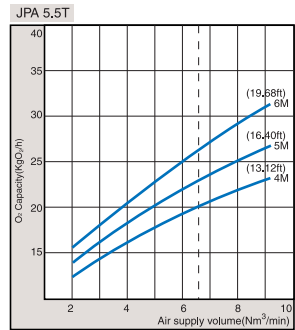

Standard model

MODEL	Output (Kw)	Air supply volume (Nm ³ /min)	O ₂ Capacity(kgO ₂ /Hr)			O ₂ Density (mmAq)	Demension (MM)										Weight (KG)
			Water depth 4(M)	Water depth 5(M)	Water depth 6(M)		A	B	C	D	E	F	d	I	J	K	
100JPA 5.5T	5.5	6.6	20	22.5	26.5	Water depth+150	1100	1670	2025	70	910	260	100A	1460	1370	1650	1000
125JPA 7.5T	7.5	9.0	28	32.0	37.0	Water depth+150	1300	1940	2345	70	1040	300	125A	1750	1630	1950	1300
150JPA 11T	11	13.5	40	47.0	53.0	Water depth+100	1560	2050	2500	70	1320	360	150A	2070	1920	2300	1400
150JPA 15T	15	18.0	56	64	73	Water depth+100	1560	2050	2500	70	1320	360	150A	2070	1920	2300	1700
200JPA 22T	22	27.0	80	95.0	110.0	Water depth+50	2200	2500	2940	100	1800	520	200A	2810	2710	3150	1800
200JPA 30T	30	36.0	110	128.0	150.0	Water depth+50	2580	2900	3430	100	2100	600	200A	3350	3150	3600	1950



Submersible Motor Pumps



JPTO

Automatic Discharge Connector(A.D.C)

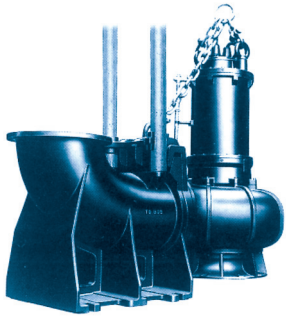

Application

- Easy to work at a place which is hard to do piping works such as sewage and waste water treatment plant
- Unnecessary to enter at the hazardous environment of sump or narrow area



Features

- The simple structure to easy to maintenance

Drawing and Parts

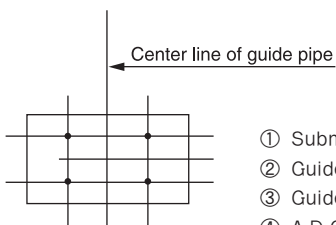
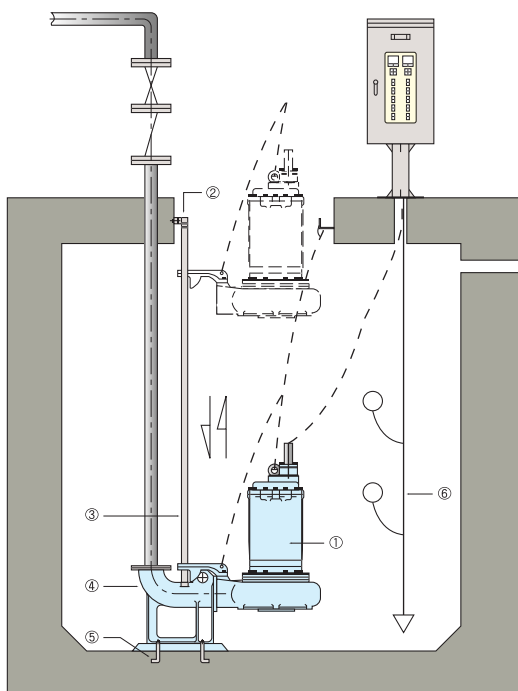

- ① Submersible Pump
- ② Guide Support
- ③ Guide Pipe
- ④ A.D.C Body
- ⑤ Anchor Bolt
- ⑥ Level Switch

MONITORING UNIT SYSTEM

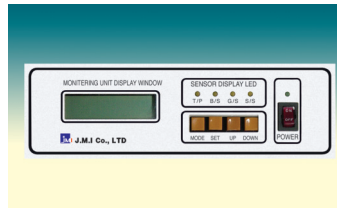

Monitoring Unit System is connected with various senses in the pump in order to protect tilting and distortion of the pump

Structure of Monitoring Unit System

- 1) Winding Temperature Sensor
 - Three temperature sensors(PT 100 Ω) detect a rise in temperature of motor
- 2) Bearing Temperature Sensor
 - Sense of bearing temperature in bearing housing
- 3) Leakage Detector, Searching Sensor
 - Float switch for detection of liquid in the stator housing or junction box

Specification and Treatment of Monitoring Unit

- 1) Technical Specification
 - Supply Power : AC220V - Ampere : 500mA
 - Frequency : 60HZ - Temperature : 0~40°C
 - Moisture : 80% - OutPut Contact : AC220V, 10A
- 2) Treatment Caution
 - Install at a place there is no water, moisture
 - Install at a place there is no vibration
 - Install at a place there is no harmful gas and high voltage or high frequency
 - Be cautious of overpower and impact

FLOAT LEVEL SWITCH



Float Level Switch can be used for starting or stopping a pump by closing or breaking the circuit when the liquid level reaches the regulator

Features

- Contact capacity is very high
- Convenient installation

Specification

- Capacity : 250 VAC 10A
- Range of used Temperature : 0°C ~50°C
- Cable Length : 3M(standard)

Connection Diagram

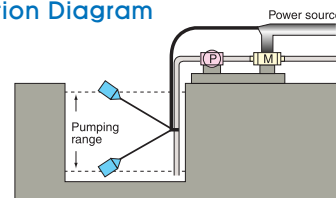

Treatment Caution

- Never operate in environment with chemical products
- If load current is higher than normal, use a magnetic switch



Submersible Motor Pumps



Technical Data For Submersible Pump Operation

Revolution (Ns)

$$N_s = N \frac{\sqrt{Q}}{H^{3/4}}$$
 N : Revolution of pump [rpm]
 H : Head [m]
 Q : Capacity [m³/min]

Impeller Type	①	②	③	④	⑤
Ns	120	180	400	900	1400
Classification	Centrifugal pump			Mixed flow pump Axial flow pump	

Total Head (M)

$$H = h + h_f$$

$$h_f = \lambda \cdot \frac{L}{D} \cdot \frac{v^2}{2g}$$

$$v = Q/A$$
 H : total head [M]
 hf : head of friction [M]
 h : actual head [M]
 λ : coefficient of friction
 g : acceleration 9.8 [m/s²]
 Q : capacity [m³/sec]
 v : m/sec
 d : diameter [M]
 A : sectional area [M²]

Discharge Diameter By Capacity

Discharge Dia(mm)	Capacity(m ³ /min)	Discharge Dia(mm)	Capacity(m ³ /min)
50	0.18~0.36	600	30~50
65	0.28~0.56	700	38~70
80	0.45~0.90	800	54~90
100	0.71~1.40	900	70~115
150	1.80~3.55	1000	90~140
200	2.8~6.0	1200	117~200
250	4.8~9.0	1350	160~255
300	7.1~14.0	1500	206~325
350	9.0~18.0	1600	250~380
400	11.2~22.4	1800	323~480
450	14.0~28.0	2000	391~600
500	18.0~35.5		

OutPut of Motor

- Hydraulic(KW) = 0.163 × H(m) × Q(m³/min) × Gravity
- 3Phase, Power(KW) = √3 × Voltage(V) × Current(A) × Efficiency(E) × Counter Current ÷ 1000
- Brake Horse Power → (Power Factor 10% = 0.1)
- Motor Power(KW) = B.H.P × (1+Power Factor)

No. of Poles and Revolution

Pole	50HZ		60HZ	
	Ns	N	Ns	N
2	3000	2850	3600	3450
4	1500	1450	1800	1750
6	1000	950	1200	1165
8	750	720	900	875
10	600	580	720	700
12	500	485	600	585
14	429	410	514	500
16	375	365	450	435
18	333	325	400	390
20	300	290	360	350

- Ns(Synchronous Speed)=(120×F)/P [rpm]
- N(Pump Revolution frequency)=Ns(1-S) [rpm]
- F : frequency(HZ)
- P : Pole
- S : Slip(%)

Capacity of Generator

- General
 - PG1(CAPACITY OF GENERATOR) = KW/0.87
 - KW : OUTPUT OF MOTOR
 - γ : EFFICIENCY OF MOTOR
- Line-Start or Y-Delta
 - PG2 = KW × K × S × 0.6
 - K : 5 - 8
 - S : D.O.L → 1
 - Y-Δ → 1/3

Starting Grade of Rotator

Grade	KVA	Grade	KVA
A	0~3.15	G	5.6~6.3
B	3.15~3.55	H	6.3~7.1
C	3.55~4	J	7.1~8
D	4~4.5	K	8~9
E	4.5~5	L	9~10
F	5~5.6	M	10~11.2

$$KVA = \frac{(\text{Voltage} \times A)}{(1000 \times \text{Horse power})} \times ST$$
 ST : 1Phase=1
 3Phase=1.732

Temperature Limitation of Motor

Insulation Class	Maximum Temperature(°C)	Temperature Limitation(°C)
A	105	60
B	135	80
F	155	100
H	185	125

Starting Method of Pump

Starting Method	Capacity
Line Start	15 [kw] ↓
Star-Delta Start	18.5 [kw] ↑ -75 [kw]
Reactor Start	90 [kw] ↑
Compensator Start	90 [kw] ↑

Cable

Circuit	Voltage	Cable Area
Single(2Line)	$e = \frac{35.6 \times L \times I}{1000 \times A}$	$A = \frac{35.6 \times L \times I}{1000 \times e}$
3Phase(3Line)	$e = \frac{30.8 \times L \times I}{1000 \times A}$	$A = \frac{30.8 \times L \times I}{1000 \times e}$
Single(3Line)/3Phase(4Line)	$e = \frac{17.8 \times L \times I}{1000 \times A}$	$A = \frac{17.8 \times L \times I}{1000 \times e}$

e : Voltage(V) · A : Cable Area(mm²) · I : Current(A) · L : Length(m)

Cable Connecting Method

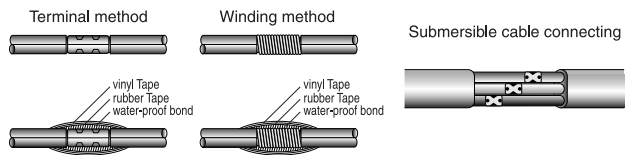

Connecting method when it is anti-phase

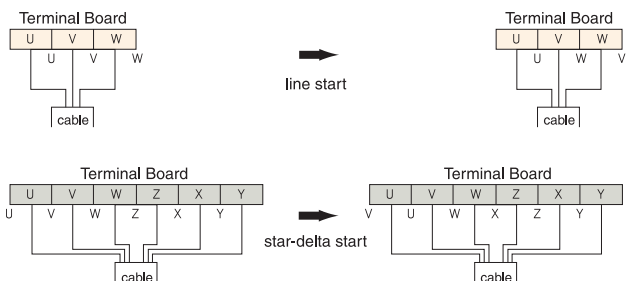



Submersible Motor Pumps



Installation type and Drawing standard

■ SUMP Dimension for Submersible Axial/Mixed Pump

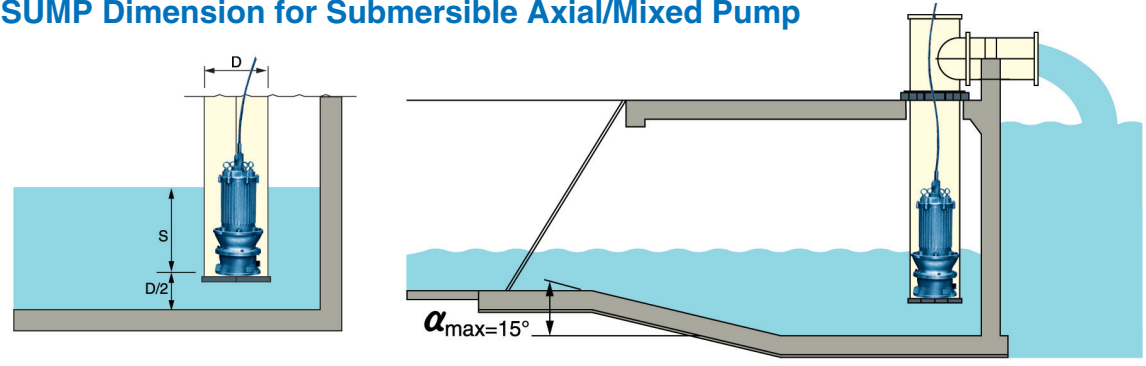

■ Single Pump Sump Layout

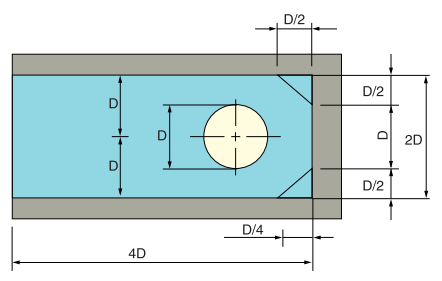

■ Multiple Pump Sump Layout

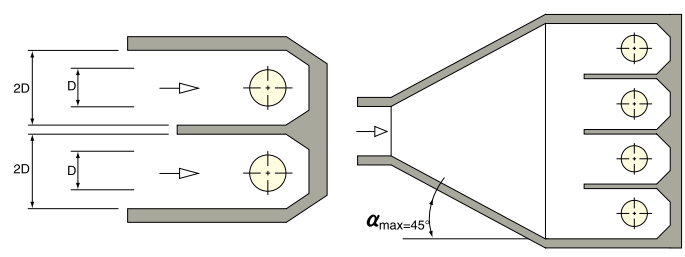



Overseas Sales Area

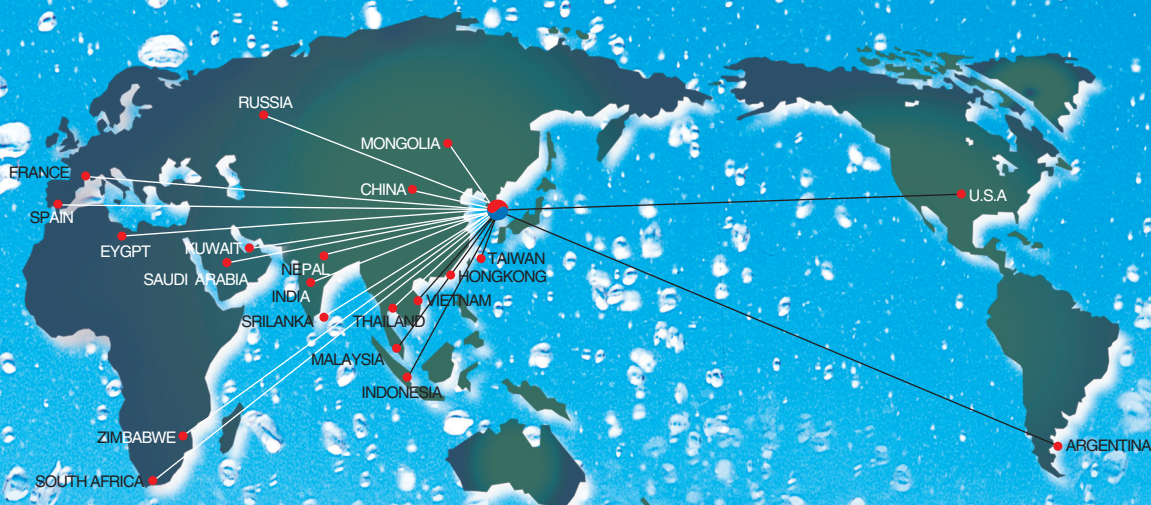

J.M.I Co., LTD

Head Office : Rm.905, WooLim Lion's Valley 3, 5445, SangDaeWon-Dong,
 JungWon-Gu, SungNam-City, KyungKI-Do, Korea
 TEL : 82-31-720-5432
 FAX : 82-31-720-5433
<http://www.jmikorea.com>

Factory : 1275-7 KwanSeul-Dong, WonJu-City, Kangwon-Do, Korea
 TEL : 82-33-761-5538
 FAX : 82-33-761-5549

<http://www.jmikorea.com>
 e-mail : jmi@jmikorea.com